



Buffalo & Fort Erie Public Bridge Authority

*Request for Pre-Qualifications for
Peace Bridge Rehabilitation Project
United States and Canada*

*1 Peace Bridge Plaza
Buffalo, New York 14213*

*100 Queen Street
Fort Erie, Ontario L2A 3S6*

Date Issued: October 16th, 2015

Submission Deadline: November 13th, 2015 1:00 PM

BUFFALO & FORT ERIE PUGLIC BRIDGE AUTHORITY
TABLE OF CONTENTS

Page

I.	INTRODUCTION.....	1
A.	General Information.....	1
B.	Restrictions on Communications.....	1
C.	Inquiries	1
D.	Modifications to the RFPQ	2
E.	Requirements.....	2
F.	Currency	4
II.	DESCRIPTION OF THE AUTHORITY AND BRIDGE.....	5
A.	Buffalo & Fort Erie Public Bridge Authority	5
B.	Peace Bridge	5
III.	SCOPE OF SERVICES.....	7
A.	General.....	7
B.	Construction.....	7
C.	Construction Management	8
IV.	TIME REQUIREMENTS	10
A.	Response Calendar	10
B.	Expected Notification and Contract Dates	10
V.	RESPONSE TO RFPQ REQUIREMENTS.....	11
A.	General Requirements.....	11
B.	Response	12
C.	Financials.....	14
VI.	EVALUATION PROCEDURES.....	16
A.	Review of Responses to RFPQ:	16
B.	Evaluation Criteria	16
C.	Oral Presentations	17
D.	Final Selection	17

VII. CONSTRUCTION CONTRACT	18
VIII. GENERAL TERMS AND CONDITIONS.....	19
A. Applicable Law	19
B. No Obligation to Proceed.....	19
C. Access to Information Legislation.....	19
D. Confidentiality of Information	21
E. No Liability re Information	21
F. No Liability - RFPQ Process.....	22
G. Rights of the Authority	22
H. Ethical Behaviour Confirmation	23
I. Restriction on Communication between Respondents.....	23
J. Verification of Information.....	24
K. Conflicts of interest.....	24
L. Request for Clarification - Conflicts.....	25
M. Respondent Team	26
IX. DEFINITIONS	27
APPENDIX A – REQUIRED INFORMATION	29
APPENDIX B – DRAWINGS	31

I. INTRODUCTION

A. General Information

The Buffalo and Fort Erie Public Bridge Authority (the "**Authority**") is issuing this Request for Pre-Qualifications ("**RFPQ**") to contractors interested in bidding on the construction of a bridge rehabilitation project at the Peace Bridge (the "**Project**"), an international border crossing connecting Fort Erie, Ontario and Buffalo, New York. The Project and this RFPQ process were authorized by a resolution of the Board of Directors of the Authority passed on October 9, 2015. This Project will require a bi-national team for construction, with experience in the laws and best practices of both Ontario, Canada and New York, U.S.A., and interested contractors shall present themselves as such in the RFPQ. It is expected that the Authority will communicate with one project manager for all work associated with the Project, and that the management team obtain by their own means appropriate work permits from U.S. Customs and Border Protection (CBP) and Canada Border Services Agency (CBSA) so that they may perform management functions in both the U.S and Canada as necessary. However, a division of construction labor at the nations' physical border will be required.

The Project is scheduled to begin in August 2016, and construction will continue for a period of three (3) years; deck replacement work will be conducted during the off-peak travel season only (October 15th through May 1st). Following each off-peak season, the contractor must return the bridge to a condition that will facilitate present traffic capacity for the peak travel season, during which miscellaneous tasks may be performed should they not impede traffic. The Project is scheduled for completion in May 2019.

The Bridge is a critical access point for cross-border traffic, both for commercial transportation and the general public. Accordingly, public use of at least 1 lane of the Bridge in each direction will need to be maintained at all times.

Capitalized terms used in this RFPQ have the meanings set out in Article IX.

B. Restrictions on Communications

From the date this RFPQ is issued until the Construction Contract award has been announced, no Respondent initiated contact with any Authority official shall be permitted regarding this RFPQ, the Request for Proposals, or the Construction Contract, other than written inquiries, as described in this section. This includes, but is not limited to, any lobbying of individuals considered to have any influence over responses to RFPQ evaluation and selection. Violation of this provision will be grounds for immediate disqualification.

C. Inquiries

All inquiries and submissions relating to the RFPQ, the Project, the Invitation to Bid or the Construction Contract by e-mail to:

Buffalo & Fort Erie Public Bridge Authority
Attention: Ms Danielle Muscat, Operations Assistant
Email: dmuscat@peacebridge.com

All questions must be made by 1:00pm EST on November 5, 2015 in order for responses to be issued before the Response submission date. Responses to questions will be posted online at www.peacebridge.com/RFQ by November 9, 2015.

Respondents must submit their Responses to this RFPQ to the Authority no later than 1:00pm EST on November 13, 2015 in the manner, and with the documents and information, specified in Part V of this RFPQ to the following address:

**Buffalo & Fort Erie Public Bridge Authority
100 Queen Street, Fort Erie, Ontario, Canada, L2A 3S6
Attention: Ms Danielle Muscat, Operations Assistant**

Respondents are responsible for all postage or courier costs, including cross-border costs, and ensuring its respective Response is received by the Authority at the address above by the time required.

Contact with the Authority or any of its personnel relating to this RFPQ, the Invitation to Bid, the Construction Contract or the Project other than as stated above may be grounds for disqualification of the Respondent from the pre-qualification process.

D. Modifications to the RFPQ

The Authority may modify any part of the RFPQ prior to the deadline for submission of responses to RFPQ by issuance of an addendum. Any addendum issued by the Authority will be posted to the Authority website and email notification of such posting will be distributed to all firms that provided contact information as requested.

E. Requirements

This Project will require a bi-national team for construction, with experience in the laws and best practices of both Ontario, Canada and New York, U.S.A., and interested contractors shall present themselves as such in response to this RFPQ. Respondents may be individuals, corporations, partnerships, limited liability companies, or joint ventures; provided that, if a Respondent is a Joint Venture Respondent, each Joint Venture Member of the Joint Venture Respondent is jointly and severally liable in connection with the RFPQ, the Invitation to Bid and the Project. The Respondent must demonstrate to the satisfaction of the Authority that the Respondent, either individually or with the combined experience and skill of its proposed Respondent Team (including Primary Subcontractors), has all the qualifications, experience and skill required to satisfy this RFPQ and perform the Work required on both sides of the Canada-US border.

Respondents must demonstrate in their Responses how the Respondent Team will satisfy and comply with relevant local laws applicable to the Work, including applicable customs and security laws.

Upon contract award, it is expected that the management team obtain by their own means appropriate work permits from U.S. Customs and Border Protection (CBP) and Canada Border Services Agency (CBSA) so that they may perform management functions in both the U.S and Canada as necessary. However, a division of construction labor at the nations' physical border will be required.

All members of the Respondent Team, as well as all of the subcontractors and suppliers of any tier which will have a physical site presence to perform any part of the Work (including construction managers, inspectors, labourers, skilled trades, operators, etc.), are required to undergo a security background review. Security reviews are conducted by CBP for individuals working in the United States and CBSA for individuals working in Canada. Individuals failing to obtain the necessary security clearances from CBP and/or CBSA will not be allowed access to the Bridge site. Delivery personnel making short term visits to the site for loading/unloading are typically exempt from this requirement. All visitors to the Authority's sites, including site visits in connection with this RFPQ process, are required to be escorted by the Authority or the Authority's representatives.

There is no expressed or implied obligation for the Authority to reimburse responding firms for any expenses incurred in preparing qualifications in response to this request.

To be considered, a Respondent must submit two (2) hard copies and one (1) electronic copy of the Response to the RFPQ, which must be received by the Authority as set out in Clause C of Part I of this RFPQ. The Authority reserves the right to reject any or all Responses to RFPQ submitted. Responses to RFPQ submitted will be evaluated by the Selection Committee of the Authority.

During the evaluation process, the Authority reserves the right, where it may serve the Authority's best interest, at any time (including after the submission date for Responses), to request additional information or clarifications from Respondents or to allow corrections of errors or omissions. At the discretion of the Authority's Selection Committee, Respondents may be requested to make oral presentations as part of the evaluation process.

All Responses become the property of the Authority. The Authority reserves the right to retain all Responses to RFPQ submitted and to use any ideas in a Response regardless of whether or not the applicable Respondent is selected. Submission of a Response indicates acceptance by the Respondent of the conditions contained in this RFPQ, unless clearly and specifically noted in the Response submitted.

All qualified Respondents will be afforded equal opportunity without discrimination because of race, creed, color, national origin, sex, age, disability or marital status. The Authority encourages minority and women-owned businesses to submit responses to RFPQ.

F. Currency

All references to dollar amounts or currency in this RFPQ are references to United States dollars, unless expressly stated otherwise. All references to dollar amounts or currency in Responses will be deemed to be references to United States dollars, unless expressly stated otherwise, except for financial statements as set out in Clause C of Part V of this RFPQ. Respondents are welcome to post dollar amounts in both Canadian and US currency, in which case the Authority may rely upon the US dollar amount.

II. DESCRIPTION OF THE AUTHORITY AND BRIDGE

A. Buffalo & Fort Erie Public Bridge Authority

The Peace Bridge is owned and operated by the Buffalo and Fort Erie Public Bridge Authority, which is an international compact entity created pursuant to a compact entered into by the State of New York, with the consent of the United States Congress, and by the Government of Canada. The Authority is governed by a ten member Board consisting of five members from New York State and five members from Canada. The mission of the Authority is to be known as the premier Canada-United States international border crossing, providing excellence in customer service and an effective conduit for trade and tourism.

The Authority's principal asset and source of revenue is the Peace Bridge, a major international toll crossing spanning the Niagara River between Fort Erie, Ontario, and Buffalo, New York. The Authority also derives significant revenues in the form of rental and fee income from the United States Bureau of Customs and Border Protection, Public Works and Government Services Canada, United States and Canadian duty-free shops, and commercial brokers operating on the property owned by the Authority and from leases of communication conduits spanning the Peace Bridge.

The Authority is authorized under its legislation to establish and collect such tolls and charges as are necessary to produce at all times sufficient revenues to meet its expenses of maintenance and operation, to pay, as the same shall become due, the principal of and interest on bonds of the Authority, and to fulfill the terms of any agreement made with the holders of the bonds until such bonds and the interest thereon are fully met and discharged.

Title to the property and assets of the Authority is vested in the Authority until July 1, 2020, or until all of the bonds issued by the Authority have been paid or discharged, whichever is later. Thereafter, the powers, jurisdiction, and duties of the Authority within the State of New York or within Canada shall be under the jurisdiction of the State of New York and Canada, respectively.

The Project and this RFPQ process were authorized by a resolution of the Board of Directors of the Authority passed on October 9, 2015.

B. Peace Bridge

The Peace Bridge is an international border crossing, carrying vehicular and pedestrian traffic across the upper Niagara River between Fort Erie, Ontario, Canada, and Buffalo, New York, United States of America. The span and substructure designations are noted on the plan and elevation drawings (Appendix B).

Original construction of the now 3-lane toll road bridge was complete in 1927. Though the structural steel was designed to accommodate two tracks of 40-ton railroad trolleys and two lanes of 20-ton trucks, the railway tracks were never constructed, and the entire roadway width (36'-0" or 11m) was used exclusively for vehicular traffic. The current

configuration includes three 12'-0" or 3.66 m wide lanes along most of the bridge's length with additional width at both ends at the approaches. During the 1950's the bridge was widened on the north and south sides of the Canadian Approach and on the south side of the United States' approach. In the year 2014 the United States' approach was further widened to the south and the Canadian approach is currently being further widened to the north.

The bridge itself is comprised of 49 spans at a length of 3,998 feet (1,219 m). Its main spans consist of five steel arches and one through truss. The approaches include nine spans on the Canadian side and seven spans on the United States' side and are made up of built up riveted girders, floorbeams and stringers. At the ends of both approaches are concrete "vaulted spans" which consist of multiple smaller spans with concrete structural support slabs. The majority of the original concrete deck remains on the steel portion of the bridge, which was overlaid with latex modified concrete approximately 20 years ago. The newly widened United States' approach consists of a monolithic reinforced concrete deck and the ongoing Canadian widening will include a partial depth grid reinforced concrete deck.

III. SCOPE OF SERVICES

A. General

The Authority is seeking qualifications from Respondents interested in bidding on the construction of a bridge rehabilitation project at the Peace Bridge, an international border crossing connecting Fort Erie, Ontario and Buffalo, NY. This Project will require a bi-national team for construction, with experience in the laws and best practices of both Ontario, Canada and New York, U.S.A., and interested contractors shall present themselves as such in the RFPQ. It is expected that the Authority will communicate with one project manager for all work associated with the Project, and that the management team obtain by their own means appropriate work permits from U.S. Customs and Border Protection (CBP) and Canada Border Services Agency (CBSA) so that they may perform management functions in both the U.S and Canada as necessary. However, a division of construction labor at the nations' physical border will be required.

The Project is scheduled to begin in August 2016, and construction will continue for a period of three (3) years; deck replacement work will be conducted during the off-peak travel season only (October 15th through May 1st). Following each off-peak season, the Contractor will return the Bridge to a condition that will facilitate present traffic capacity for the peak travel season, during which miscellaneous tasks may be performed should they not impede traffic. The Project is scheduled for completion in May, 2019.

B. Construction

Bridge rehabilitation construction work (the "Work") will include but will not be limited to the following:

1. Steel structure

- Complete replacement of the structural slab, from abutment to abutment
 - Proposed deck will be a cast-in-place partial depth grid reinforced concrete deck
- Widening of the structure including the addition of a pedestrian walkway/bikeway and observation platform
- Structural steel replacement, rehabilitation and strengthening
- Installation of underside shielding for the majority of the bridge's length
- Installation of electrical and fiber infrastructure
- Complete replacement of roadway traffic signage
- Installation of new architectural traffic control gantries

- New decorative steel railings and light posts
- Extensive maintenance and protection of traffic arrangements

2. Concrete Approach Spans

- Complete removal of all existing overlays of varying thickness and type (i.e. bituminous concrete, cement concrete, granite pavers, etc.)
- Miscellaneous concrete partial-depth repairs to vertical, overhead and horizontal surfaces
- Demolition and reconstruction of portions of the deck slabs, bents and longitudinal walls due to the addition of a pedestrian bikeway and modifications to the north maintenance access pathway
- Miscellaneous expansion joint repairs
- Reconfiguration of begin and end approaches to the new pedestrian bikeway
- Overlay of both Canadian and American approach vault spans

The enclosed drawings show the general area and scope of the Work (Appendix B).

C. Management

The contractor will be in general responsible for, but not limited to, the following management services:

- Construction management for the entire project in both the United States and Canada
- Holding all subcontracts necessary for the performance of the work
- Reporting to the Authority designee on all project matters including scope and schedule and as otherwise defined within the Invitation to Bid
- Material and personnel logistics across the international border
- Maintenance and protection of traffic within the identified project zone as defined in the Invitation to Bid
- Traffic control within the identified project zone as defined within the Invitation to Bid

- Compliance with both CBP and CBSA border agency security requirements
- Delivering a completed project as defined within the Invitation to Bid

Only pre-qualified Respondents will be invited to bid on the Project and be provided with the Invitation to Bid and Construction Contract.

IV. TIME REQUIREMENTS

A. Response Calendar

The following is a list of key dates up to and including the date Responses to RFPQ are due to be submitted:

RFPQ issued	October 16, 2015
Due date for submission of questions	November 5, 2015 at 1:00 PM
Questions to be answered	November 9, 2015
Due date for Responses to RFPQ	November 13, 2015 at 1:00 PM

B. Expected Notification and Contract Dates

Short-listed firms notified	November 20, 2015
Presentations/interviews of short-listed Respondents	Week of November 23, 2015
Prequalified Respondents notified	December 11, 2015
90% Design Drawings issued to Prequalified Respondents	Week of December 14, 2015
Draft Construction Contract issued to Prequalified Respondents	Week of December 14, 2015
Due date for submission of questions, and of comments and proposed revisions to Construction Contract	February 12, 2016
Invitation to Bid (including final Construction Contract)	Week of February 22, 2016
Submission of Bids	April 1, 2016
Award of Contract	May 2, 2016
Construction Commencement	Week of August 1, 2016

The Authority reserves the right to alter the timetable at any time and will provide notice of any changes to Respondents to this RFPQ.

V. RESPONSE TO RFPQ REQUIREMENTS

A. General Requirements

1. **Inquiries** – Inquiries concerning the RFPQ and the subject of the RFPQ must be made in accordance with Clause C of Part I of this RFPQ. Contact with the Authority or any of its personnel relating to this RFPQ, the Invitation to Bid, the Construction Contract or the Project other than in accordance with Clause C of Part I may be grounds for disqualification of the Respondent from the pre-qualification process.
2. **Addenda: Errors and Omissions** – Respondents discovering any ambiguity, conflict, discrepancy, omission or other error in this RFPQ should immediately notify, prior to the due date for Responses, the contact person set forth in Section V.A.1 and advise of such error and request clarification or modification of the document. Modifications to this RFPQ will be issued by addenda and clarifications will be communicated by written notice to each party that submitted their intentions to respond.

If a Respondent fails to notify the Authority prior to the due date for Responses of a known error or an error that reasonably should have been known, the Respondent assumes all risk in its Response and its Bid relating to such error.

3. **Submission of Responses to RFPQ** – The following material is required to be included in all Responses and received by November 13, 2015, 1:00 PM for a Respondent to be considered:
 - a. Two (2) hard copies and one electronic copy of the response to RFPQ to include the following:
 - (i) *Title Page* – Title page showing the RFPQ subject; the Respondent's name; the name, address, and telephone number of the contact person; and the date the Response is submitted.
 - (ii) *Table of Contents*
 - (iii) *Transmittal Letter* – A signed letter of transmittal briefly stating the Respondent's understanding of the general work to be completed, an affirmative statement that the bi-national team requirement is met, and a statement why the Respondent believes itself to be best qualified to perform the engagement. The transmittal letter should also state the name, telephone number and e-mail address of the official within the Respondent who will serve as the Authority's primary contact concerning the Response. An unsigned response will be rejected. If a Respondent is a Joint Venture Respondent comprised of multiple Joint Venture Members, only one primary contact will be identified and that contact will have the authority to

speak for all Joint Venture Members of the Joint Venture Respondent.

- (iv) *Detailed Qualification Response* – The detailed Response should follow the order set forth in Section V. B. of this RFPQ.

B. Response

- 1. General Requirements** – The purpose of the Response is to demonstrate the qualifications, competence and capacity of the Respondent Team seeking to undertake services in conformity with the requirements of this RFPQ and to perform the Work on both sides of the Canada-US border. As such, the substance of the Response will carry more weight than its form or manner of presentation. The Respondent should demonstrate the qualifications of all of the proposed Respondent Team, including Primary Subcontractors and all Joint Venture Members and of the particular staff to be assigned to this engagement.

The Response should address all the points outlined in the RFPQ. The Response should be prepared simply and economically, providing a straightforward, concise description of the Respondent's capabilities to satisfy the requirements of the RFPQ. While additional data may be provided by the Respondent in its Response, the following subjects, item Nos. 2 through 11, must be included in all Responses. They represent the criteria against which the Response will be evaluated. Responses are limited to twenty-five (25) pages, excluding the title page, table of contents, transmittal letter, and requested resumes, prepared as single-sided pages on 8 1/2 x 11 inch paper using at least 10 point type with standard margins.

For clarity purposes, the Authority requests that each Respondent restate each question, with the answer stated directly below each question.

- 2. Independence and Ethical Practices** – The Respondent must provide an affirmative statement that it is, and each Respondent Team Member (including each Joint Venture Member of the Joint Venture Respondent and Primary Subcontractors) is, independent of and dealing at arm's length with the Authority, is not in breach of the Authority's Ethics Policy, and will avoid any actual or perceived conflict of interest. Conflict of interest is defined as a situation in which a person is, or could reasonably be perceived to be, in a position to benefit more preferentially than in an open market situation. The Authority will provide copies of its Ethics Policy upon request by Respondents.
- 3. Team Structure** – This Project will require a bi-national Respondent Team for construction, with experience in the laws and best practices of both Ontario, Canada and New York, U.S.A. The Respondent must provide information on the Respondent Team structure (including planned Primary Subcontractors), showing that this requirement is satisfied, as well as the structure of the Joint Venture Respondent, if the Respondent is a Joint Venture Respondent. It is expected that the Authority will communicate with one project manager for all work associated with the Project, however, a division of construction labor at the nations' physical border will be required.

Respondents may be individuals, corporations, partnerships or Joint Ventures. If a Respondent has any question regarding its proposed Respondent Team structure and what Joint Venture Members, Primary Subcontractors or affiliated entities need to be identified and information provided, please contact the Selection Committee in the manner described in Clause C of Part I.

The Authority is open to considering a variety of Respondent Team structures; provided, however, (a) if the Respondent is not a legal entity, it must act through one or more of its Joint Venture Joint Venture Members that are legal entities; (b) all Respondent Team Members (including any of their affiliates) must only be a Respondent Team Member of only one Respondent Team; and (c) Respondents must provide a copy of a written agreement or agreements signed by all Respondent Team Members and all Joint Venture Members agreeing to the proposed Respondent Team structure and Joint Venture Respondent structure, respectively, which agreement or agreements may be a formal teaming agreement, or term sheet, but must be binding on the Respondent Team Members and Joint Venture Members, as applicable. Any changes to the Respondent Team Members or the Joint Venture Members after the date a Respondent's Response is submitted must be approved by the Authority in accordance with Clause M of Part VIII of this RFPQ.

4. **Licensed to Practice** – Each Respondent Team Member (including each Joint Venture Member if the Respondent is a Joint Venture Respondent) performing any part of the Work must provide an affirmative statement that each one is properly licensed (or capable of being, and not barred from becoming, licensed) to carry on business in the State of New York and the Province of Ontario, as applicable, and as otherwise required to complete the Project.
5. **Disciplinary Actions** – Each Respondent Team Member (including each Joint Venture Member if the Respondent is a Joint Venture Respondent) must provide information on the circumstances and status of any disciplinary action taken or pending against such member during the past five (5) years with federal (Canadian and American), provincial, state regulatory bodies or professional organizations.
6. **Firm Qualifications and Experience** – The Respondent must include the information set out in Appendix A for each Respondent Team Member (including each Joint Venture Member if the Respondent is a Joint Venture Respondent).
7. **Experience of Project Manager and Key Staff** – The Respondent should identify the project manager and key staff for the assignment and detail the following:
 - a. General qualifications: general education, training, length of experience, positions held, time with firm, and so forth.
 - b. Adequacy for assignment: experience in specific sector or field.
 - c. Experience in region: knowledge of local issues.

- d. Provide resumes for key professional staff who would be assigned to this engagement.
8. **Similar Project Experience** – The Respondent must describe the nature and scope of similar projects managed by the proposed project manager.
9. **Prior Engagements with the Buffalo & Fort Erie Public Bridge Authority** – For each Respondent Team Member (including each Joint Venture Member if the Respondent is a Joint Venture Respondent), list separately all engagements, within the last five (5) years, with the Authority by type of engagement. Indicate the scope of work, date, the location of the Respondent’s office from which the engagement was performed, and the name and telephone number of the principal client contact.
10. **Similar Engagements with other Entities** – For the Respondent Team Member’s personnel that will be assigned responsibility to perform the Work, list the most significant engagements that are similar to the engagement described in this request for qualifications. Indicate the scope of such work, dates and duration of service and the name and telephone number of the principal client contact. From these engagements, provide at least three (3) references containing contact name, address and telephone number.
11. **Distinguishing Features** – The Respondent shall identify and describe the most important attributes that distinguish your team from competing teams, and how those attributes will benefit the Authority.

C. Financials

1. For each Respondent (including each Joint Venture Member if the Respondent is a Joint Venture Respondent), attach the following:
 - a. the organization’s most recent audited financial statements, including the auditor’s opinion, balance sheet, income statement, statement of cash flows, and footnotes;
 - b. the organization’s most recent internal unaudited financial statements, including the balance sheet and income statement; and
 - c. the organization's most recent internal cash flow statement.

If the organization does not prepare annual audited financial statements, and so is not able to comply with Clause 1.a above, please inform the Authority. The Authority reserves the right, exercisable in its sole and complete discretion, to waive the requirement for audited financial statements, and to require additional or alternative means of independently verifying the financial information provided by, and financial status of, the Respondent organization.

If the financial statements are not issued in the name of the Respondent organization:

- explain the relationship between the Respondent organization and the organization for whom financial statements were attached; and
 - indicate whether the organization for whom financial statements were attached is willing and able to serve as a guarantor of any future construction contract entered into by the Respondent organization.
- 2.** For each Respondent (including each Joint Venture Member if the Respondent is a Joint Venture Respondent), attach a letter from its surety insurer indicating the bid, performance, and payment bond single and aggregate limit that would be provided in the event that the Construction Contract was executed.
 - 3.** Financial statements must indicate the applicable currency used in such financial statements. For financial statements only, references to dollars or currency will not be deemed to be references to United States dollars.

VI. EVALUATION PROCEDURES

A. Review of Responses to RFPQ:

The Authority's Selection Committee will review qualifications of the Responses. Respondent Teams with unacceptably low technical qualifications will be eliminated from further consideration. Short-listed Respondents, with their Respondent Teams, will be asked to participate in an interview process to further evaluate qualifications.

B. Evaluation Criteria

Responses will be evaluated using three sets of criteria. The following represent the principal non-exhaustive selection criteria, which will be considered during the evaluation process.

1. Mandatory Elements

- a. The Respondent and all members of the Respondent Team are independent from, and deal at arm's length with, the Authority, and have no conflict of interest with regard to any other work performed for the Authority.
- b. The Respondent adequately addresses actual and disciplinary actions pending before any regulatory or professional licensing authority or agency.
- c. The Respondent adheres to the instructions in this RFPQ on preparing and submitting the Response, including all requirements set out in the General Terms and Conditions in Part VIII.

2. Technical Quality

- a. Expertise and Experience
 - (i) The Respondent Team's qualifications and past experience and performance on similar engagements.
 - (ii) Project manager and key staff qualifications and past experience and performance on similar engagements.
 - (iii) The Respondent Team's approach towards identifying and resolving potential problems/challenges in providing the services requested.
 - (iv) The Respondent Team's distinguishing and value-added services.

3. Financials

The Respondent must submit the financial information as required in Clause C of Part V of this RFPQ in accordance with either Generally Accepted Accounting Principles in the United States (US GAAP) or International Financial Reporting Standards (IFRS), consistently applied, which standard must be expressly indicated on the financial statements. Internal (unaudited) financial information should be consistent with the principles used in the presentation of the audited financial statements submitted. Any variations from the indicated standard must be expressly noted and explained in Notes to the financial statements.

The following are some key considerations that may be used in evaluating the Respondent Team's general financial status:

- Earnings
- Cash Flow / Liquidity
- Balance Sheet and financial flexibility considerations
- Financial volatility
- Creditworthiness

The above key considerations identify areas that may be used to evaluate a Respondent Team's general financial status and risk are not exhaustive, and are not meant to be the only financial items considered in evaluating the suitability of the Respondent Team for pre-qualification.

C. Oral Presentations

Short-listed Respondents will be asked to participate in an interview/presentation process. Such interviews/presentations will provide Respondents with an opportunity to answer any questions that the Selection Committee may have on a Respondent's Response. Not all Respondents may be asked to make such oral presentations.

D. Final Selection

The Authority will select a Respondent based upon the recommendation of the Authority's Selection Committee.

It is anticipated that pre-qualified Respondents will be selected by December 11, 2015. It is further expected that prequalified Respondents will receive 90% Design Bid Documents and the draft Construction Contract in December 2015, to begin review in advance of the invitation to bid, which is to be issued in February 2016.

In accordance with the policy approved by the Board of Directors of the Authority, the Authority's Selection Committee will not conduct debriefing sessions with unsuccessful Respondents.

VII. CONSTRUCTION CONTRACT

The Construction Contract will be issued to pre-qualified Respondents only.

Pre-qualified Respondents will be permitted an opportunity to comment on the Construction Contract prior to submitting its Bid, but its Bid will be based upon the final Construction Contract issued by the Authority. The Authority anticipates issuing the initial draft Construction Contract shortly after the selection of pre-qualified Respondents, and the final draft Construction Contract in February 2016.

The winning Respondent will enter into a single fixed-price Construction Contract with the Authority for all of the Work, including all of the Work on both sides of the border. The winning Respondent will be permitted to enter into one or two separate subcontracts covering the Work to be performed in each of Canada and the United States; however, it will be a requirement that Work performed in the United States must be performed by a contractor residing in the United States, and Work performed in Canada must be performed by a contractor residing in Canada, which may be an entity incorporated for the purpose of the Project.

The Construction Contract will exclude design of the Project, but include all work and services required to perform and complete the Work and services for the Project, including obtaining all required licenses, permits, approvals and authorizations (except for certain ones that remain the Authority's responsibility), all labour and materials, and all testing and commissioning and compliance with all health, safety, security and customs laws while performing the Work applicable to the location where the Work is performed.

VIII. GENERAL TERMS AND CONDITIONS

The following General Terms and Conditions apply throughout this RFPQ and to the Response. Any change or amendment to the terms and conditions of this RFPQ are of no effect unless set out in a written Addendum to this RFPQ issued by the Authority.

A. Applicable Law

This RFPQ, and any contract, which may subsequently arise from this RFPQ, shall be governed by the law of the United States of America, as applicable to an international compact entity. The appropriate jurisdiction for any disputes which arise from the RFPQ or any contract which may arise from this RFPQ, shall be the United States District Court for the Western District of New York.

The section titles are for convenience only and shall not be construed to affect the meanings of the sections titled.

B. No Obligation to Proceed

Nothing in this RFPQ obliges the Authority in any way to proceed to issue the Invitation to Bid, award a Construction Contract or proceed with the Project. The Authority may terminate this pre-qualification process at any time and proceed with the Project, in whole or in part, in the same or some other manner, including reissuing the same or a different RFPQ in relation to the Project. This RFPQ does not constitute an offer to enter, or obligate the Authority to enter, into a contract with any person and is not intended to create any binding contract, often referred to in Canada as Contract "A".

C. Access to Information Legislation

1. In fulfilling its public service responsibilities, the Authority adopted a policy and procedure (the "**FOIL/AIA Policy**") for responding to requests for information, including requests made pursuant to the New York or Federal *Freedom of Information Law* ("**FOIL**") and the Canadian *Access to Information Act* ("**AIA**"). While the Authority is not subject to either FOIL or the AIA, the Authority does voluntarily respond to requests for information and gives effect to the principle that the public has a right to know.
2. In accordance with the FOIL/AIA Policy, the Authority will make available for public inspection and copy all records except those that the Authority denies access to or portions thereof that:
 - (a) are rendered confidential or privileged or are exempted from disclosure by Federal or state law in the United States or provincial or Federal statutes of Canada;
 - (b) if disclosed, would constitute an unwarranted invasion of personal privacy (including as this concept is given effect in the *Personal Protection Privacy*

Act (Canada) and the Personal Information and Electronic Documents Act (Canada)) as more particular set out in the FOIL/AIA Policy;

- (c) if disclosed, would impair present or future contract awards or collective bargaining or negotiations of leases, permits, contracts or other agreements;
- (d) are confidential trade secrets or financial, commercial, scientific or technical information of the Authority or a third party (including a governmental entity) that if disclosed could cause substantial injury to the competitive position of the Authority or such party;
- (e) are compiled for public safety, law enforcement or official investigatory purposes (internal and external) and which, if disclosed, may affect public safety, interfere with proceedings, or deny or prejudice a right to a fair trial or impartial negotiation, or identify a confidential source or disclose confidential information relating to an audit or a civil, criminal, or internal or external disciplinary investigation;
- (f) if disclosed, would endanger the life or safety of any person;
- (g) are in any way related to the security of the Bridge or property associated with federal government functions;
- (h) if disclosed, would jeopardize the Authority's capacity to guarantee the security of its information technology assets, such assets encompassing both electronic information systems and infrastructures;
- (i) are materials of any governmental agency (state, local, municipality, region, public authority) other than statistical or factual tabulations of data, specific instructions given to staff, final approved policies and all external audits where these materials or instructions are not exempted;
- (j) are photographs, microphotographs, videotape or other recorded images that could impact upon personal privacy;
- (k) that contains information that was obtained in confidence from the government of a foreign state or institution thereof, an international organization of states or institution thereof, the government of a province, municipality or region or institutions thereof or an aboriginal government (as defined in Nisga'a Final Agreement Act);
- (l) is subject to a solicitor-client or attorney-client privilege;
- (m) if disclosed, could affect, impact or be expected to prejudice the competitive position of a government institution (which may include the Authority) or specific business entities with which government institutions (which may include the Authority) deals.

3. In submitting any document, information or other record to the Authority, including the Response, each Respondent acknowledges and accepts the FOIL/AIA Policy. Except as expressly set out in this RFPQ or the FOIL/AIA Policy, all documents, information and other records submitted in response to this RFPQ will be considered confidential. However, such information or parts thereof may be released pursuant to FOIL/AIA Policy. Respondents are also advised that FOIL/AIA Policy may provide protection for confidential and proprietary business information. Respondents are advised to consult their own legal advisors as to the appropriate way in which confidential or proprietary business information should be marked as such in their Responses.
4. Subject to the provisions of the FOIL/AIA Policy, the Authority will use reasonable efforts to safeguard the confidentiality of any information identified by the Respondent as confidential but the Authority shall not be liable in any way whatsoever to any Respondent or Respondent Team Member if such information is disclosed pursuant to the FOIL/AIA Policy.

D. Confidentiality of Information

Pre-qualified Respondents will be required to enter into a confidentiality agreement.

E. No Liability re Information

1. This RFPQ may not contain all of the information that a Respondent may need in deciding whether to submit a Response. The Authority accepts no responsibility for any Person lacking any information.
2. The Authority will not be liable for any information or advice or any errors or omissions that may be contained in this RFPQ or the data, materials or documents (electronic or otherwise) provided to the Respondents or prospective Respondents in the RFPQ process or otherwise with respect to the Project.
3. The Authority make no representations or warranties and there are no representations, warranties or conditions, either express or implied, statutory or otherwise, in fact or in law, with respect to the accuracy or completeness of this RFPQ or the data, materials or other documents referred to in Clause 5(b). The Authority will not be responsible for any claim whatsoever arising from a Respondent's or prospective Respondent's reliance on or use of this RFPQ or any such data, materials or other documents which are provided, delivered, made available or required by the Authority.
4. Each Respondent and prospective Respondent is responsible for obtaining its own independent legal, financial, engineering, architectural, environmental and other technical or professional advice, and making its own investigations with respect to the Project, this RFPQ, the RFPQ process and any data, materials or other documents provided, delivered or made available or required by the Authority or its Representatives. Submission of a Response is deemed to be conclusive evidence that the Respondent has made such investigations and has obtained such

advice and that the Respondent is willing to assume and does assume all risks affecting the Project, except as otherwise specifically stated in this RFPQ.

F. No Liability - RFPQ Process

The Authority does not, by issuing this RFPQ or by any communication or documentation made or provided in connection with this RFPQ, incur any duty of care or contractual obligation to any Person.

G. Rights of the Authority

The Authority may at any time, with or without notice:

- 1.** reject and not consider a Response from a Respondent, or disqualify any Respondent where (i) the Respondent or any Respondent Team Member (including any Joint Venture Member if the Respondent is a Joint Venture Respondent) has been disqualified from a procurement process undertaken by the Authority as the result of any criminal charges related to inappropriate bidding practices or unethical behaviour (ii) there are any outstanding criminal charges related to inappropriate bidding practices or unethical behaviour by a Respondent or a Respondent Team Member or any of their Affiliates in relation to a public or broader public sector tender or procurement in any jurisdiction (iii) there is evidence satisfactory to the Authority that, based on past conduct or behaviour, the Respondent or any or a Respondent Team Member is unsuitable or has conducted themselves improperly or (iv) the Authority determines that the Respondent or any or a Respondent Team Member performance on other contracts is sufficiently poor to jeopardize the completion of the Project;
- 2.** consider, in the evaluation of a Response, (i) any dispute involving a Respondent or Respondent Team Member and (ii) any instances of poor performance of a Respondent or Respondent Team Member, or any other unfavourable experiences with any of them, that the Authority has experienced;
- 3.** amend the scope or details of the Project, or modify, cancel, amend, supplement, clarify or suspend the whole or any part of the Project, this RFPQ, the RFPQ process or any or all stages of the pre-qualification or Invitation to Bid process;
- 4.** reissue a request for qualifications for the Project the same as this RFPQ or a different request for qualifications document in connection with the Project;
- 5.** reject or disqualify all or any Responses or Respondents;
- 6.** waive any material or non-material deficiency or failure to comply with the requirements of this RFPQ; and
- 7.** prior to the issuance of the Invitation to Bid, replace a pre-qualified Respondent which has informed the Authority that it does not intend to participate in the Invitation to Bid process by inviting another Respondent, based on its ranking in this RFPQ process, to be added to the list of pre-qualified Respondents who will

participate in the Invitation to Bid process if, in the opinion of the Authority, it will serve the interest of the Authority on the Project to do so.

H. Ethical Behaviour Confirmation

Without limitation of any other rights of the Authority or the requirements of this RFPO, in order to ensure the integrity, openness and transparency of the pre-qualification process, the Authority may:

1. impose at any time on all Respondents and any Respondent Team Member additional conditions, requirements or measures, with respect to bidding practices or ethical behaviour of a Respondent and any of the members of the Respondent Team; and
2. require that any or all Respondents and/or any Respondent Team Member at any time during the pre-qualification process provide the Authority with copies of its internal policies, processes and controls establishing ethical standards for its bidding practices and evidence of compliance by the Respondent and all Respondent Team Members with such policies, processes and controls.

In the event that any Respondent and/or Respondent Team Member:

3. fails to comply with any requirement prescribed by the Authority pursuant to this Clause H; or
4. complies with the Authority's requirement as prescribed in accordance with this Section, but the Authority determines that any Respondent and/or Respondent Team Member has or may have engaged in inappropriate bidding practices or unethical behaviour, the Authority shall have the right, at any time to reject and not consider a Response from a Respondent.

I. Restriction on Communication between Respondents

A Respondent shall not discuss or communicate, directly or indirectly, with any other Respondent, any information whatsoever regarding the preparation of its own Response or the Response of another Respondent. Each Respondent shall prepare and submit its Response independently and without any connection, knowledge, comparison of information, or arrangement, direct or indirect, with any other Respondent. The Respondent shall ensure that its key individuals and members of Respondent Team and their respective representatives and Affiliates comply with this Clause I. By submitting a Response, a Respondent on its own behalf and as authorized agent of each Respondent Team Member, key individual and their respective representatives and affiliates represents, warrants and confirms to the Authority that its Response has been prepared and submitted without collusion or fraud, or in violation of any applicable law and in fair competition with prospective Respondents, prospective Respondent Teams, and other Respondents.

J. Verification of Information

The Authority may independently verify any information received in or in respect of any Response pursuant to this RFPQ. The Authority may disqualify any Respondent whose Response:

1. contains any false or misleading information; or
2. fails to disclose any information that would, if disclosed, materially adversely affect the Authority's evaluation of such Respondent's Response.

K. Conflicts of interest

1. For the purposes of this RFPQ, the term "conflict of interest" includes any situation or circumstance which is a conflict of interest under the Authority's Ethics Policy or where a Respondent, a Respondent Team Member, their respective Representatives and affiliates and/or a key individual of a Respondent Team Member, has, could be perceived to have or could possibly acquire:
 - contractual or other obligations to the Authority or any the Authority Party that could or could be seen to have been compromised or impaired as a result of its participation in the RFPQ process, the Invitation to Bid process or the Project; or
 - knowledge or information (other than information disclosed by the Authority in the normal course of the RFPQ process) of strategic and/or material relevance to the RFPQ process or to the Project that is not available to other Respondents and that could or could be seen to give the Respondent an unfair competitive advantage.
 - commitments, relationships, financial interests or involvement in ongoing litigation:
 - that could or could be seen to exercise an improper influence over the objective, unbiased and impartial exercise of the Authority's independent judgment;
 - that could or could be seen to compromise, impair, challenge, be in opposition to or be incompatible with the Project or the effective performance of the Authority's obligations under this RFPQ, the Invitation to Bid or the Construction Contract; or
 - in which the Authority is an adverse party.

In determining conflict of interest, the Authority may consider and have regard to relevant codifications in Canada and the US such as, in the US, 23 CFR 1.33 and 23 CFR 636.116 and, in Canada, the Code of Conduct for Procurement (2014-11-27) of Public Works and Government Services Canada (referenced later in this RFPQ).

2. Each Respondent must use its best efforts to avoid any conflict of interest in relation to the Project, and comply with any requirements prescribed by the Authority to mitigate or resolve any conflict of interest which may arise.
3. Throughout the RFPQ process and Invitation to Bid process, each Respondent shall and it shall ensure that its Respondent Team Members and their respective representatives and affiliates and key individuals, promptly disclose to the Authority in writing any conflict of interest. At the time of such disclosure, the Respondent shall include any information and documentation that demonstrates appropriate measures have been or will be implemented to mitigate, minimize or eliminate the conflict of interest. The Respondent shall provide such additional information and documentation and implement such additional measures as the Authority may require in connection with the Authority's consideration of the conflict of interest and proposed measures.
4. The Authority may waive any and all conflicts of interest. A waiver must be in writing and may be upon such terms and conditions as the Authority requires to ensure that the conflict of interest has been appropriately managed, mitigated and minimized including requiring the Respondent and/or its Respondent Team Members to put into place such policies, procedures, measures and other safeguards as may be required by and be acceptable to the Authority to manage, mitigate and minimize the impact of such conflict of interest.
5. The Authority may immediately disqualify a Respondent or require a Respondent to remove and/or replace a Respondent Team Member and/or key individual, if, in each case as determined by the Authority, the Respondent fails to disclose a conflict of interest, the Respondent fails to comply with any requirements prescribed by the Authority to mitigate or resolve a conflict of interest, or the conflict of interest issue cannot be mitigated or otherwise resolved.
6. The determination of the Authority as to whether a conflict of interest exists shall be final and binding.

Should any of the above language conflict with the Authority's existing policies, the Authority's policies shall prevail.

L. Request for Clarification - Conflicts

A prospective Respondent or Respondent Team Member or advisor of a Respondent who has any concerns regarding whether a current or prospective employee, advisor or a Respondent Team Member of that Respondent has or may have a conflict of interest, is encouraged to request an advance ruling in accordance with this Section through the following process may, on a confidential basis, request a "clarification from the Authority by submitting an inquiry in accordance with Clause C of Part I of this RFPQ, and providing all relevant information The Authority may request additional information. The Authority will not be held liable for any determination on verification issued in relation to conflicts of interest on possible conflicts of interest or possible conflicts of interest.

M. Respondent Team

- 1.** Respondent Team Members, including affiliates of Respondent Team Members, may not be Respondent Team Members of any other Respondent, unless (a) the Authority expressly approves in advance, (b) a Respondent Team Member is removed from one Respondent Team in accordance with this Clause M, or (c) the Respondent is not pre-qualified and joins a Respondent that has been pre-qualified in accordance with this Clause M.
- 2.** If a Respondent wishes to remove, add or otherwise change a Respondent Team Member (including any Joint Venture Member if the Respondent is a Joint Venture Respondent) after the submission of its Response, then it must first obtain the written approval of the Authority, which approval may be granted in the Authority's sole discretion. In making its determination to grant or deny such approval, the Respondent will provide the Authority with such information, documents and other records as the Authority may request, including all information, documents and other records required under this RFPQ and all agreements and amendments to agreements demonstrating the amended Respondent Team structure.
- 3.** A Change in Control of a Respondent Team Member is deemed to be a change to such Respondent Team Member for the purposes of this Clause M, and requires the approval of the Authority.

IX. DEFINITIONS

The following terms have the meanings set out below:

"Authority" has the meaning set out in Clause A of Part I of this RFPQ.

"Bid" means the bid to be submitted in response to the Invitation to Bid.

"Bridge" or **"Peace Bridge"** means the bridge connecting Canada and the United States from Fort Erie, Ontario to Buffalo, New York and known as the Peace Bridge, as more particularly described in Part II of this RFPQ.

"Change of Control" means, in respect of any Respondent Team Member (including a Joint Venture Member if the Respondent is a Joint Venture Respondent), any direct or indirect change, which results in another person, or another group of persons acting jointly or in concert, which did not control such Respondent Team Member person directly or indirectly immediately prior to the change, controlling such Respondent Team Member after such change.

"Construction Contract" means the construction contract to be entered into by the Authority and the Contractor to perform the Work.

"Contractor" means the Respondent whose Bid is selected by the Authority in accordance with the Invitation to Bid.

"control" means, with respect to any person, the ability to control the management and direction of such person and such person is deemed to be controlled by another person if controlled in any manner whatsoever that results in control in fact by that other person (or that other person and any person or persons with whom that other person is acting jointly or in concert), whether directly or indirectly, and whether through the ownership of securities, a trust, a contract or otherwise, and **"controlling"** has a similar extending meaning.

"Ethics Policy" means the Authority's Business Ethics Policy issued August 5, 2004, as amended or replaced from time to time, which will be made available by the Authority upon request.

"Invitation to Bid" means the Invitation to Bid to be issued by the Authority to pre-qualified Respondents in order to select a Contractor to perform the Work under the Construction Contract.

"Joint Venture" means, for the purposes of this RFPQ:

- (a) a partnership;
- (b) a limited liability company;
- (c) an unincorporated joint venture of two or more corporations or partnerships; and
- (d) a Joint Venture Corporation.

"Joint Venture Corporation" means a corporation established for the purposes of this Project and for preparing a Response where the legal or beneficial interest of such corporation is

controlled or held by two or more unaffiliated corporations, partnerships or limited liability companies.

"Joint Venture Respondent" means a Respondent that is a Joint Venture.

"Joint Venture Member" means, for the purposes of this RFPQ:

- (a) the partners of a Joint Venture Respondent that is a partnership, including a limited partnership or limited liability partnership;
- (b) the members of a limited liability company;
- (c) the joint venture partners of a Joint Venture Respondent that is an unincorporated joint venture; and
- (d) the person or persons who control a Joint Venture Respondent that is a Joint Venture Corporation.

"Primary Subcontractors" means the primary subcontractors which will enter into subcontracts with the Contractor for performance of a material part of the Work and upon whose experience and skill the Respondent is relying as a Respondent Team Member in order to satisfy the requirements of this RFPQ.

"Project" has the meaning set out in Clause A of Part I of this RFPQ.

"Respondent" means an individual, corporation, or Joint Venture intending to submit, or submitting a Response, including a Joint Venture Respondent and its Joint Venture Members.

"Respondent Team" means the Respondent, including its Joint Venture Members in the case of a Joint Venture Respondent, and the Respondent's proposed Primary Subcontractors.

"Respondent Team Member" means the members of the Respondent Team, including its Joint Venture Members in the case of a Joint Venture Respondent, and the Respondent's proposed Primary Subcontractors.

"Response" means a written response to be submitted in response to this RFPQ in the manner, time and form required in this RFPQ.

"RFPQ" has the meaning set out in Clause A of Part I of this RFPQ.

"Work" means all of the construction work and services, and related work, required to complete the Project, as will be more particularly defined in the Construction Contract; but, for greater certainty, includes all of the work and services described in Part III of this RFPQ, health and safety, coordination and management of traffic on the Bridge during construction periods, and testing and commissioning.

APPENDIX A

REQUIRED INFORMATION

Each Respondent must provide the following information in respect of each Respondent Team Member (including each Joint Venture Member if the Respondent is a Joint Venture Respondent):

- (a) Respondent Team Member's name, location of headquarters, location of office from which services would be rendered to the Authority;
- (b) description of the Respondent Team Member, including ownership structure, number of partners and employees, number of years in business, and a brief description of the services the Respondent Team Member offers;
- (c) list the Respondent Team Member's completed and active projects as contractor for the last five (5) years, and include information in the following format:
 - (i) name of client
 - (ii) number of years serving this client
 - (iii) name of project manager(s) in charge of this client
 - (iv) brief description of services provided
 - (v) location and type of the project
 - (vi) commencement and completion dates
 - (vii) value of the construction work
- (d) describe Respondent Team Member's service standards, how they are measured, and how service issues are reviewed;
- (e) disclose if a Respondent Team Member has ever been debarred by any US Federal or state authority;

In providing its description of experience and skills, Respondents should describe and demonstrate any experience:

- (a) on multi-national projects, particularly with scope in North America;
- (b) in working on a project crossing international borders;
- (c) with procuring significant quantities of materials and other supplies;
- (d) in the construction of roads and pavement;

- (e) in working with public or governmental authorities to obtain required approvals in a multi-jurisdiction environment;

Respondents in their Responses should also demonstrate an understanding of the key role that the Bridge will play in the conduct and promotion of efficient trade between Canada and the US, and the importance of the Project for the Authority and for both Canada and the US.

APPENDIX B

DRAWINGS

See attached for the following drawings, enclosed for reference:

- Aerial view of project site
- General Plan and Elevation (1 through 8)
- Canadian Approach Typical Cross Section
- Arch Spans Typical Cross Section
- Truss Span Typical Cross Section
- United States Approach Cross Section (1 through 3)



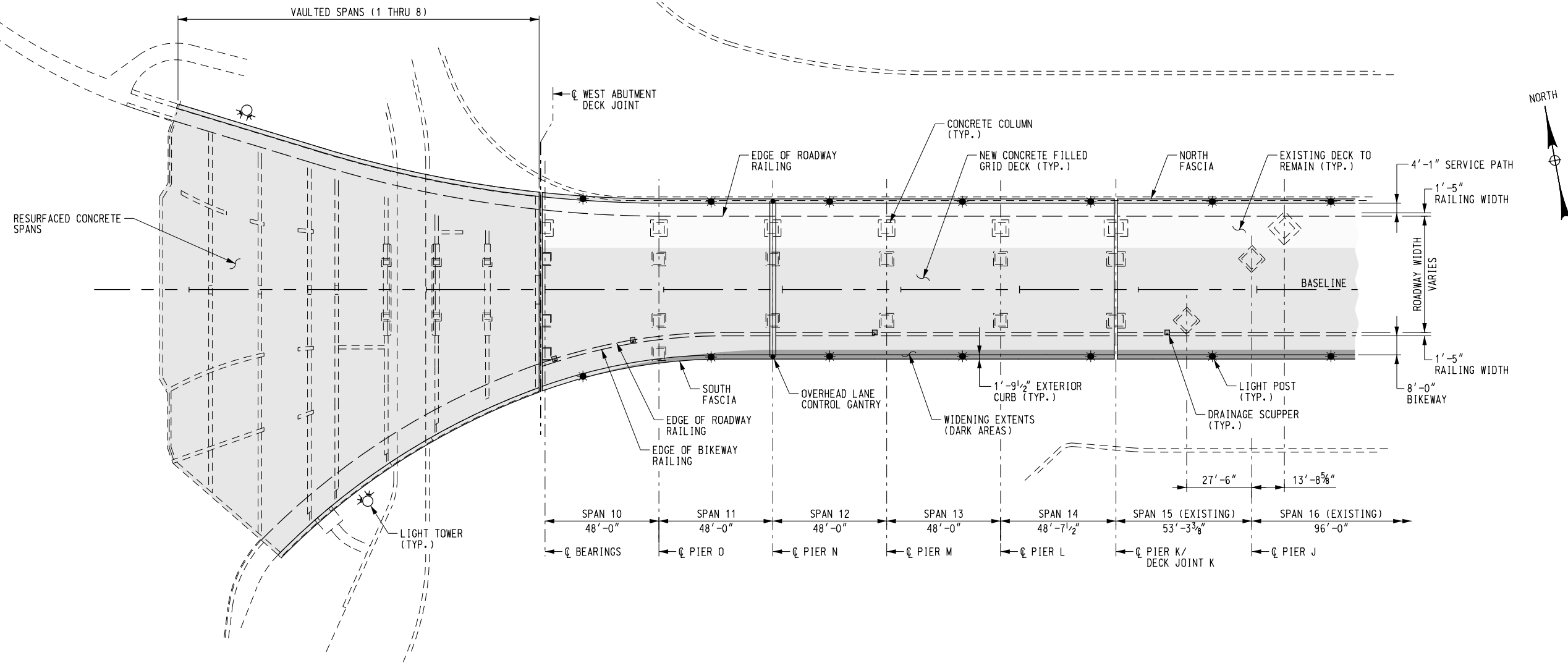

PLAN

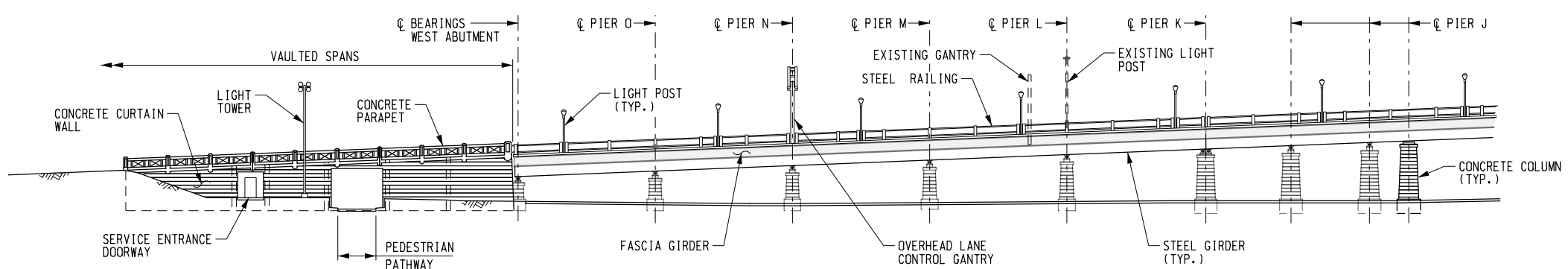

ELEVATION

NOT FOR CONSTRUCTION

 BUFFALO AND FORT ERIE PUBLIC BRIDGE AUTHORITY	SCALE: N.T.S.	SHEET NO.
	DATE: OCT 2015	1 OF 14

GENERAL PLAN AND ELEVATION
(1 OF 8)

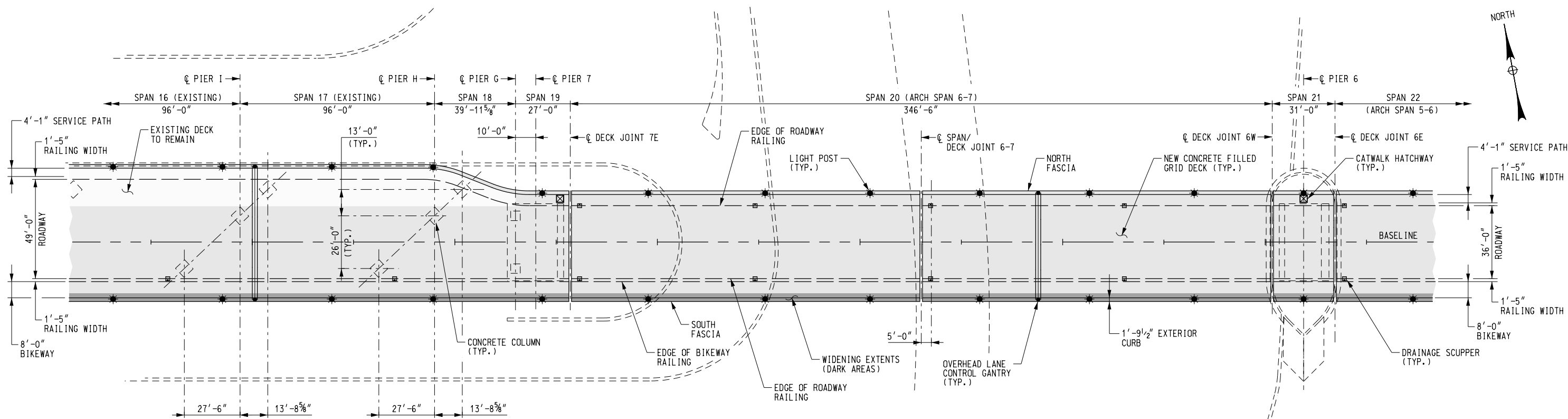

PLAN

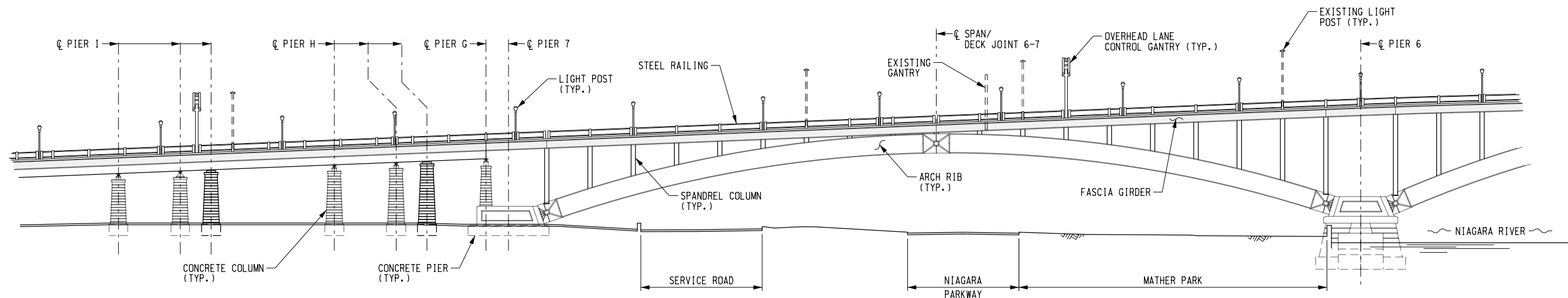

ELEVATION

NOT FOR CONSTRUCTION

 BUFFALO AND FORT ERIE PUBLIC BRIDGE AUTHORITY	SCALE: N.T.S.	SHEET NO.
	DATE: OCT 2015	2 OF 14

GENERAL PLAN AND ELEVATION
(2 OF 8)

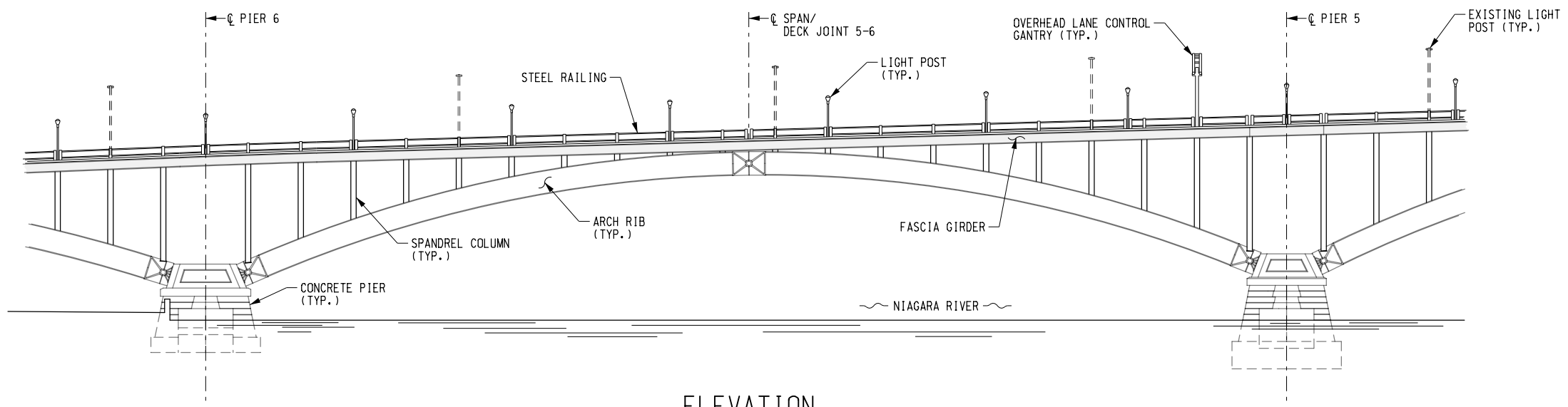
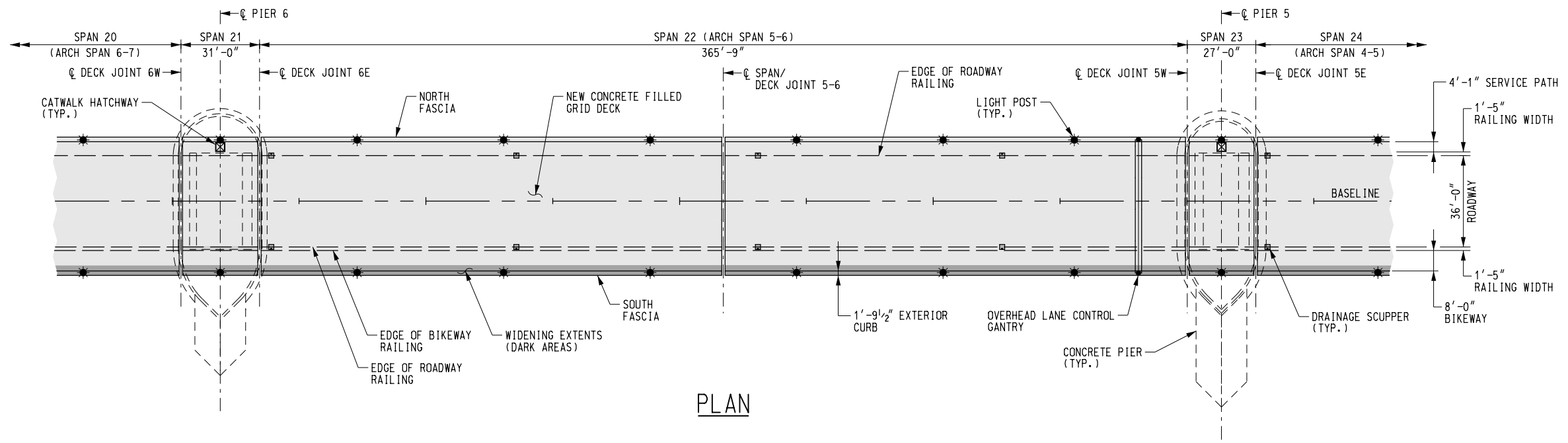

NOT FOR CONSTRUCTION

 BUFFALO AND FORT ERIE PUBLIC BRIDGE AUTHORITY	SCALE: N.T.S.	SHEET NO.
	DATE: OCT 2015	3 OF 14

GENERAL PLAN AND ELEVATION
(3 OF 8)

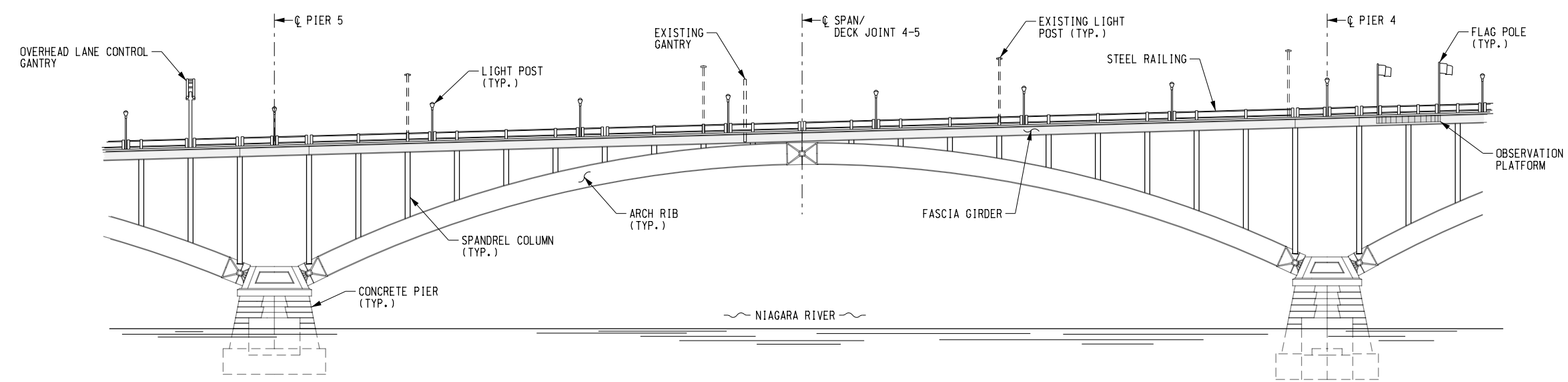
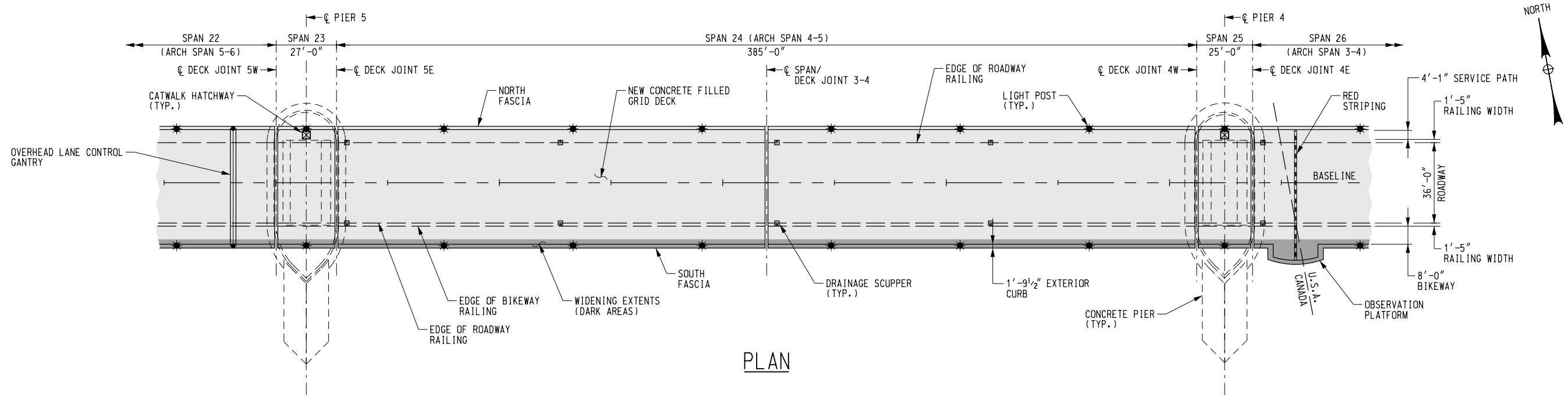

NOT FOR CONSTRUCTION

 BUFFALO AND FORT ERIE PUBLIC BRIDGE AUTHORITY	SCALE: N.T.S.	SHEET NO.
	DATE: OCT 2015	4 OF 14

GENERAL PLAN AND ELEVATION
(4 OF 8)

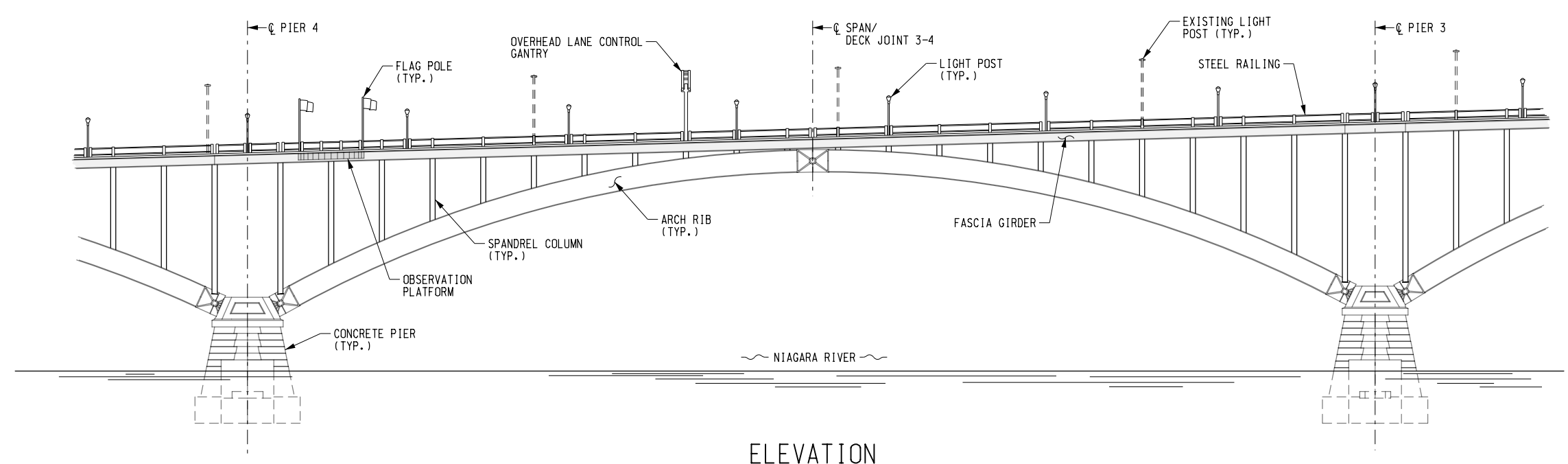
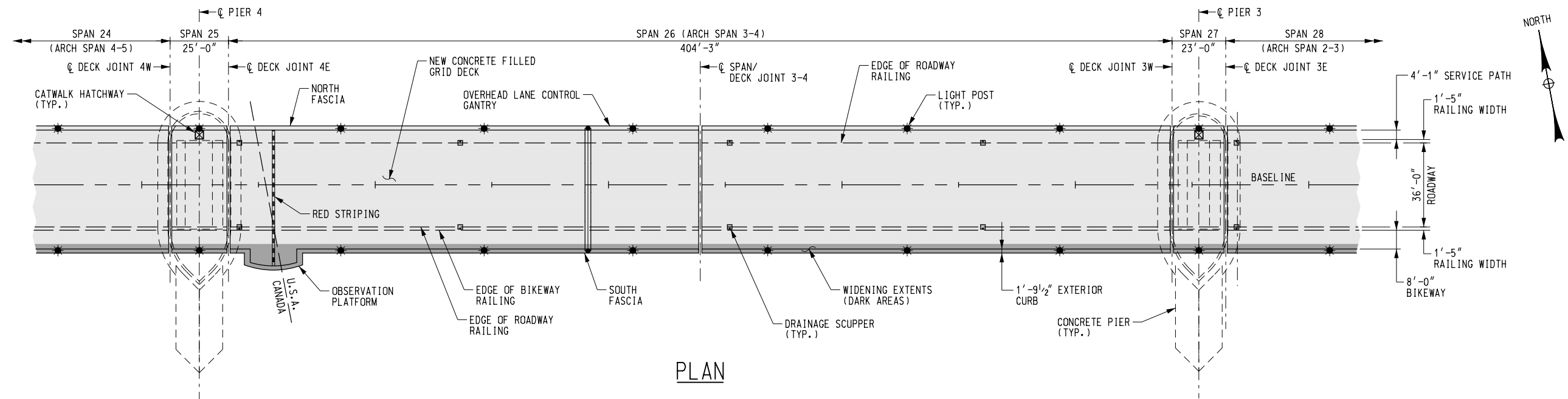

NOT FOR CONSTRUCTION

 BUFFALO AND FORT ERIE PUBLIC BRIDGE AUTHORITY	SCALE: N.T.S.	SHEET NO.
	DATE: OCT 2015	5 OF 14

GENERAL PLAN AND ELEVATION
(5 OF 8)

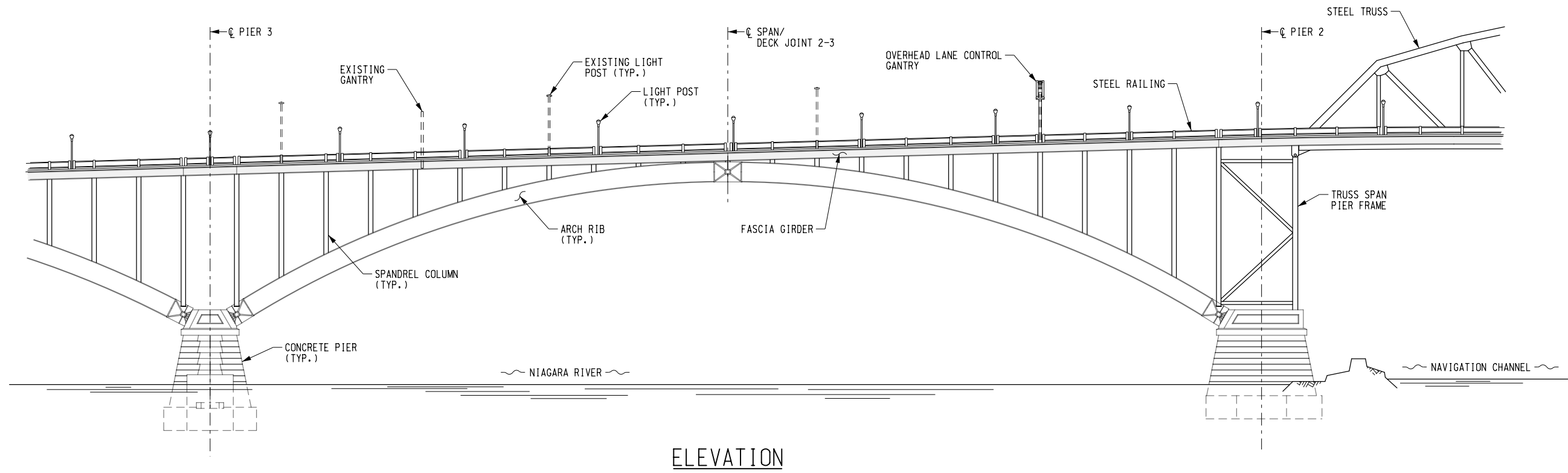
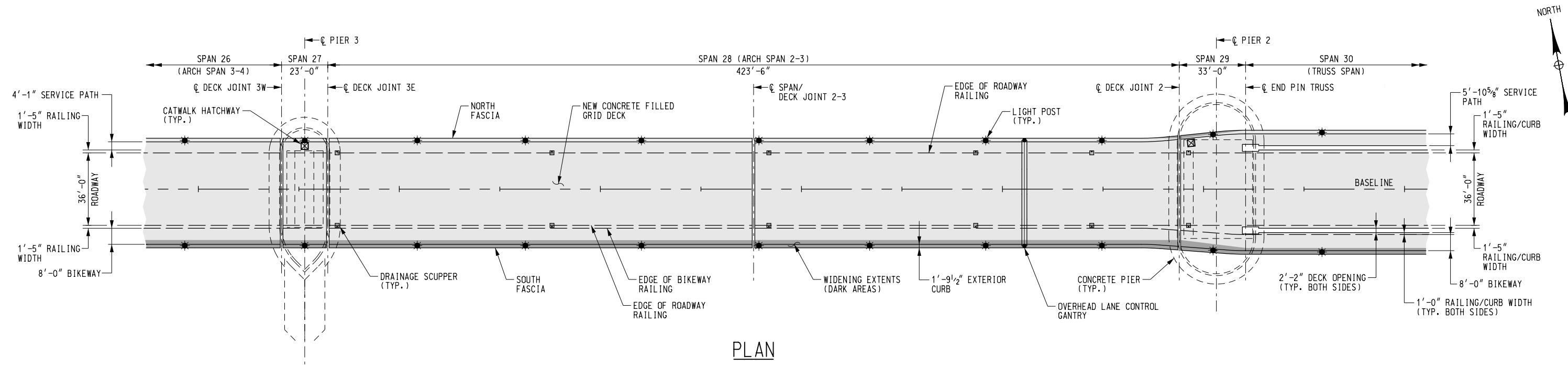

NOT FOR CONSTRUCTION

 BUFFALO AND FORT ERIE PUBLIC BRIDGE AUTHORITY	SCALE: N.T.S.	SHEET NO.
	DATE: OCT 2015	6 OF 14

GENERAL PLAN AND ELEVATION
(6 OF 8)

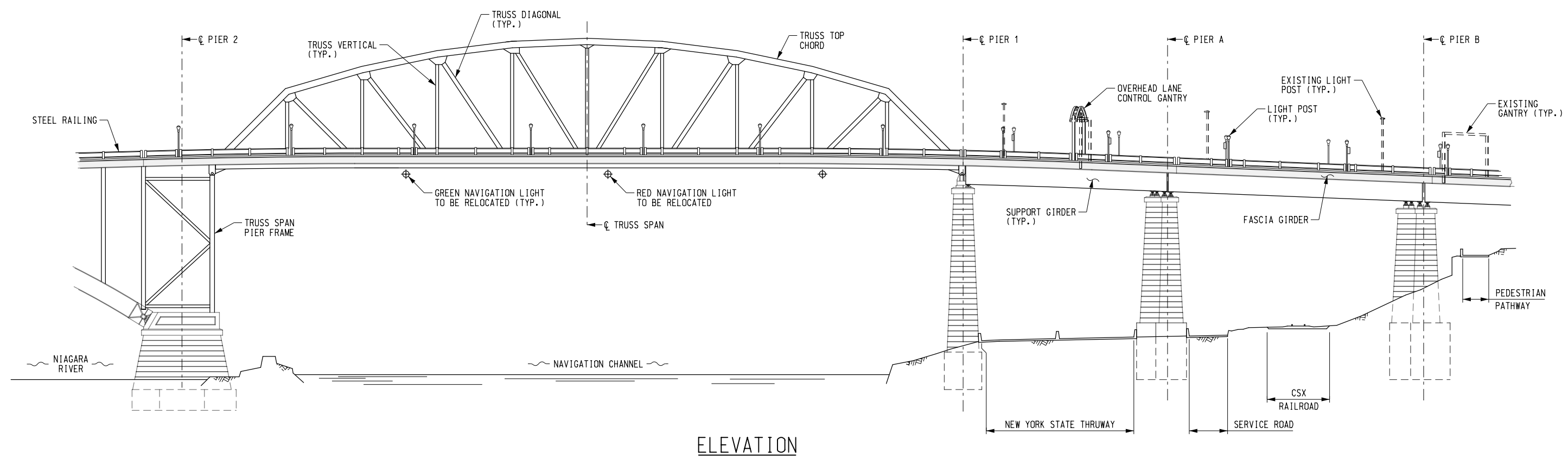
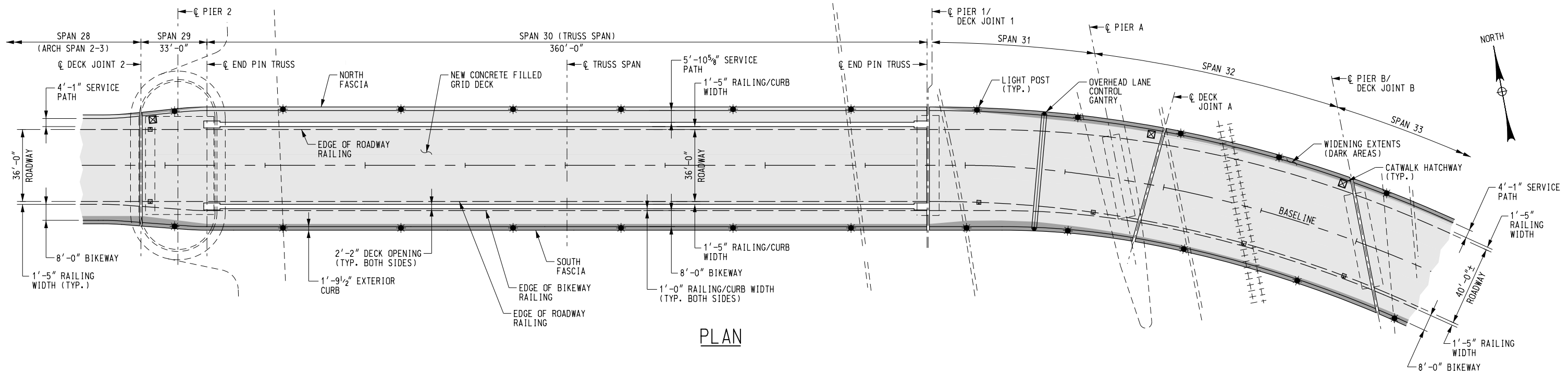

NOT FOR CONSTRUCTION

 BUFFALO AND FORT ERIE PUBLIC BRIDGE AUTHORITY	SCALE: N.T.S.	SHEET NO.
	DATE: OCT 2015	7 OF 14

GENERAL PLAN AND ELEVATION (7 OF 8)

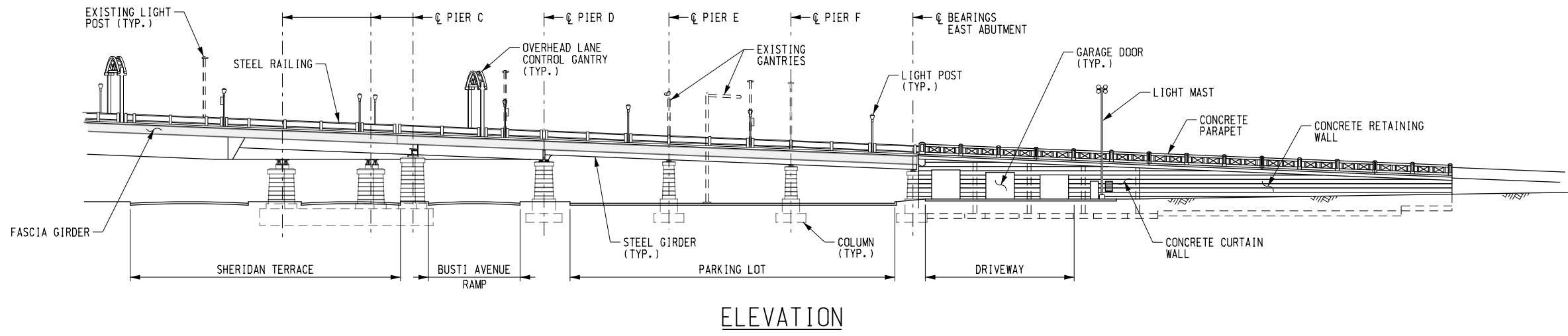
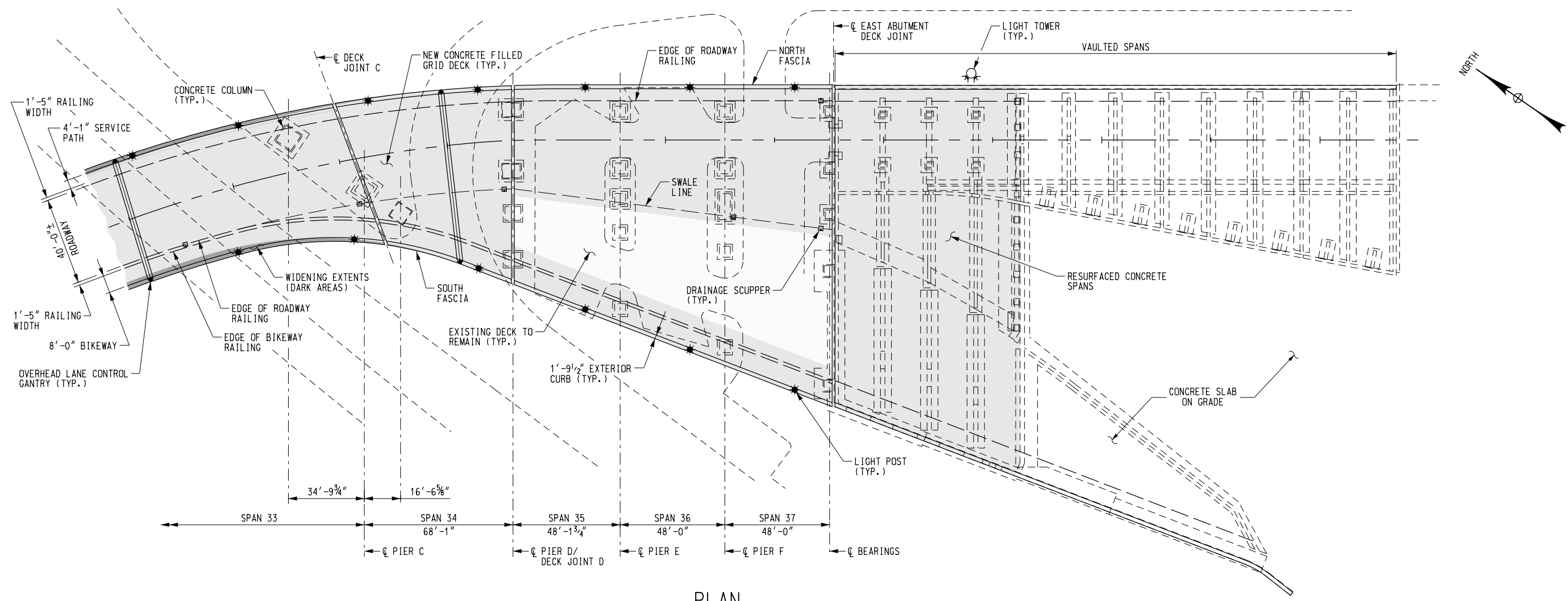

NOT FOR CONSTRUCTION

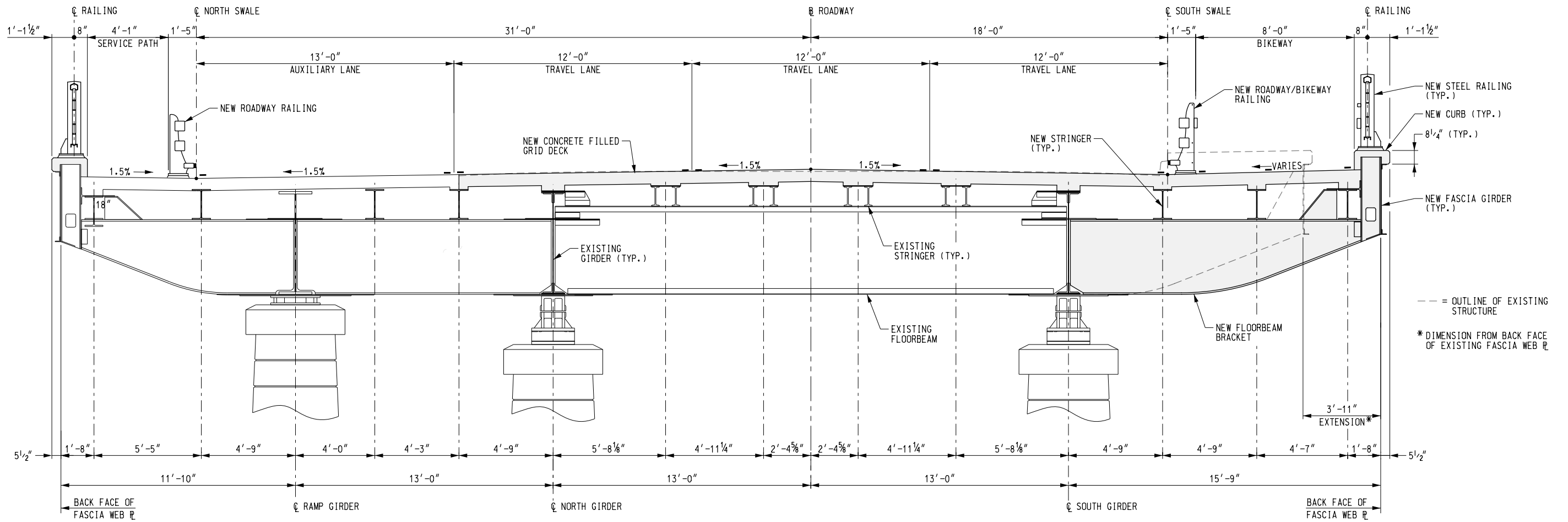

TYPICAL CROSS SECTION
SCALE: 3/16"=1'-0"

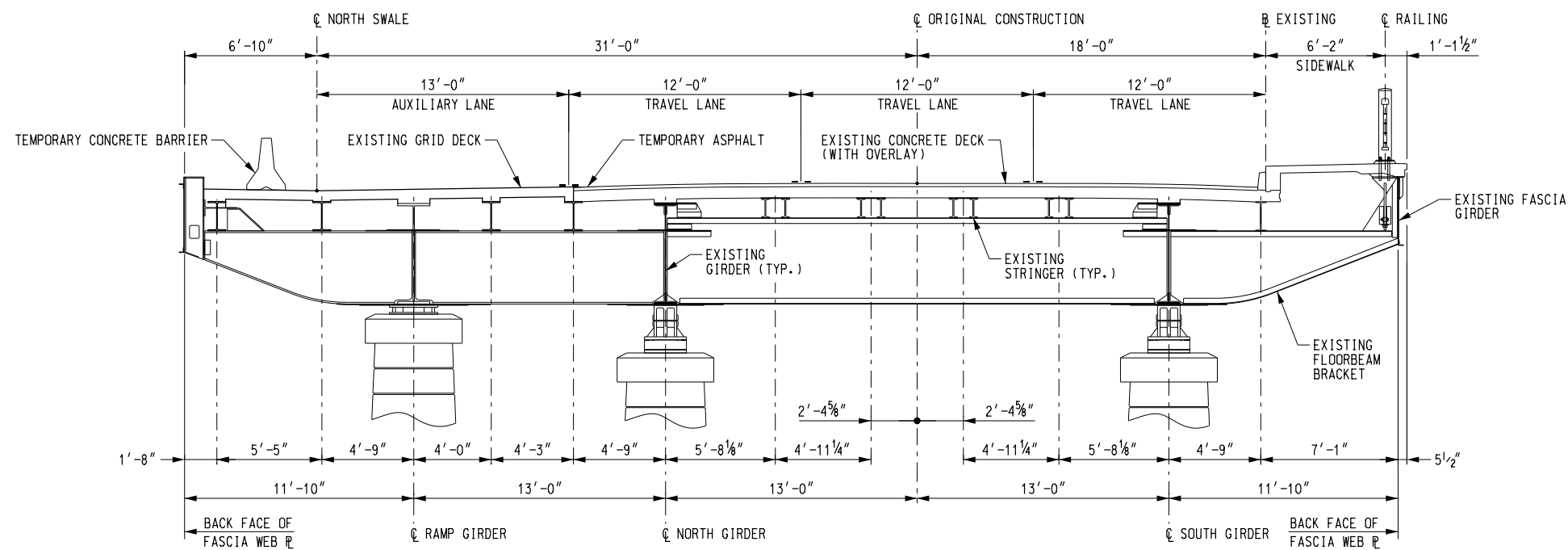

TYPICAL EXISTING CROSS SECTION
SCALE: 1/8"=1'-0"

NOT FOR CONSTRUCTION



BUFFALO AND FORT ERIE
PUBLIC BRIDGE AUTHORITY

CANADIAN APPROACH
TYPICAL CROSS SECTION

SCALE: N.T.S.
DATE: OCT 2015

SHEET NO.
9 OF 14

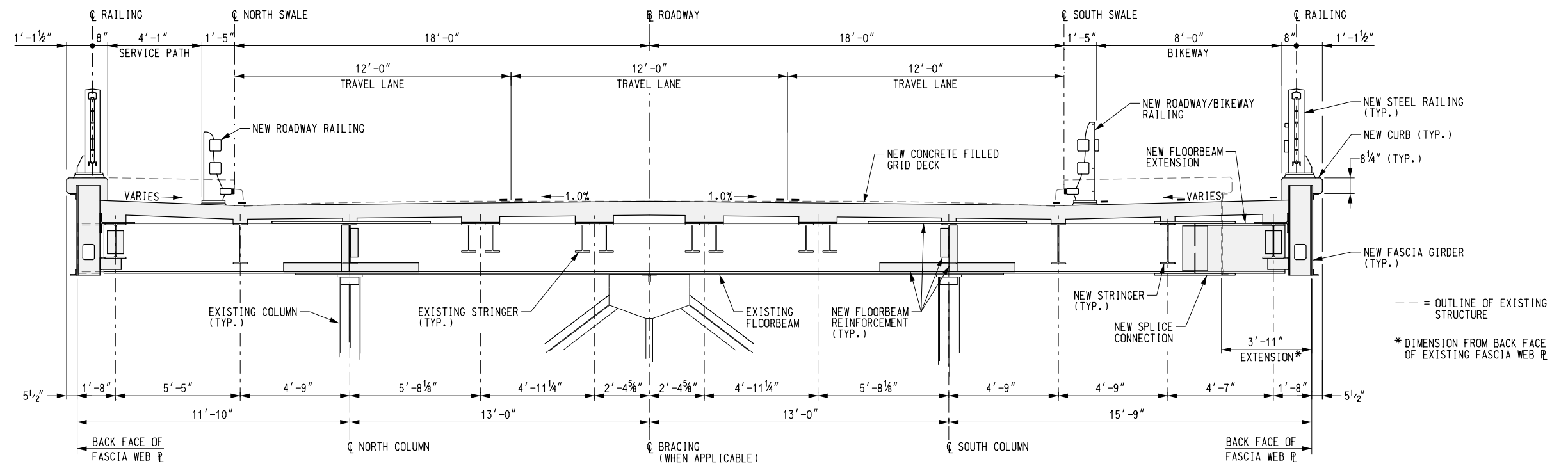

TYPICAL CROSS SECTION
SCALE: 3/16"=1'-0"

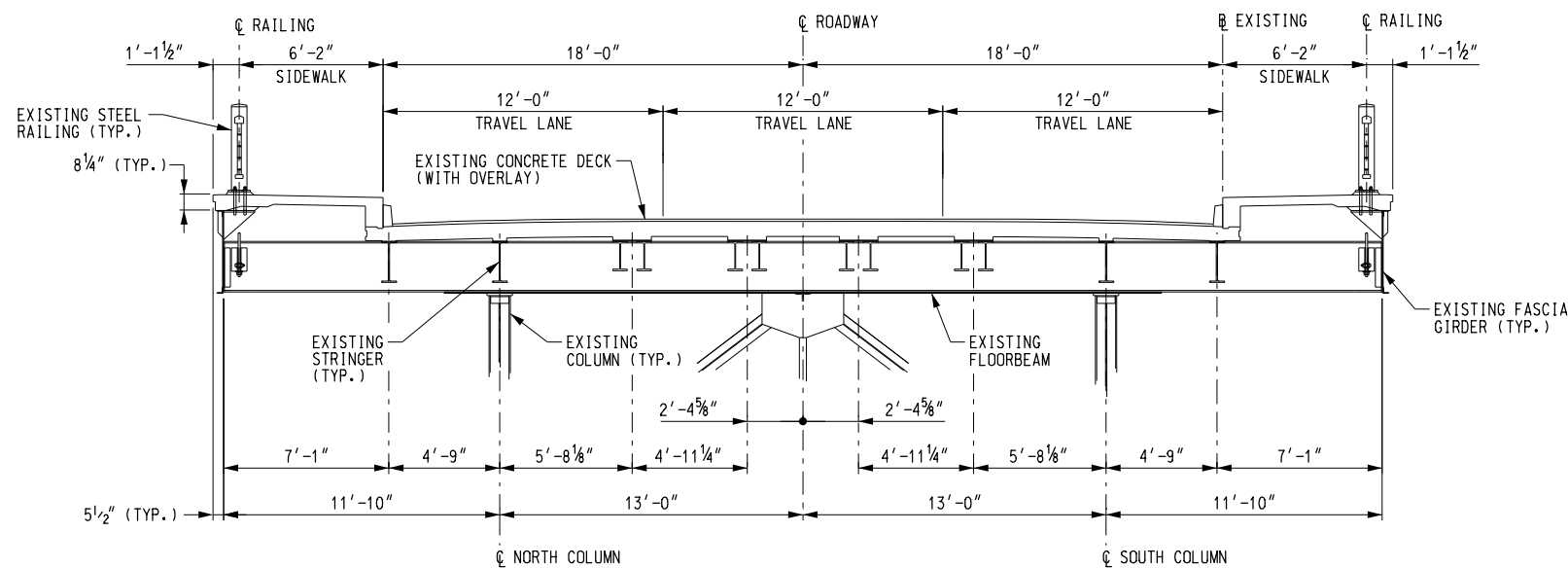

TYPICAL EXISTING CROSS SECTION
SCALE: 1/8"=1'-0"

NOT FOR CONSTRUCTION

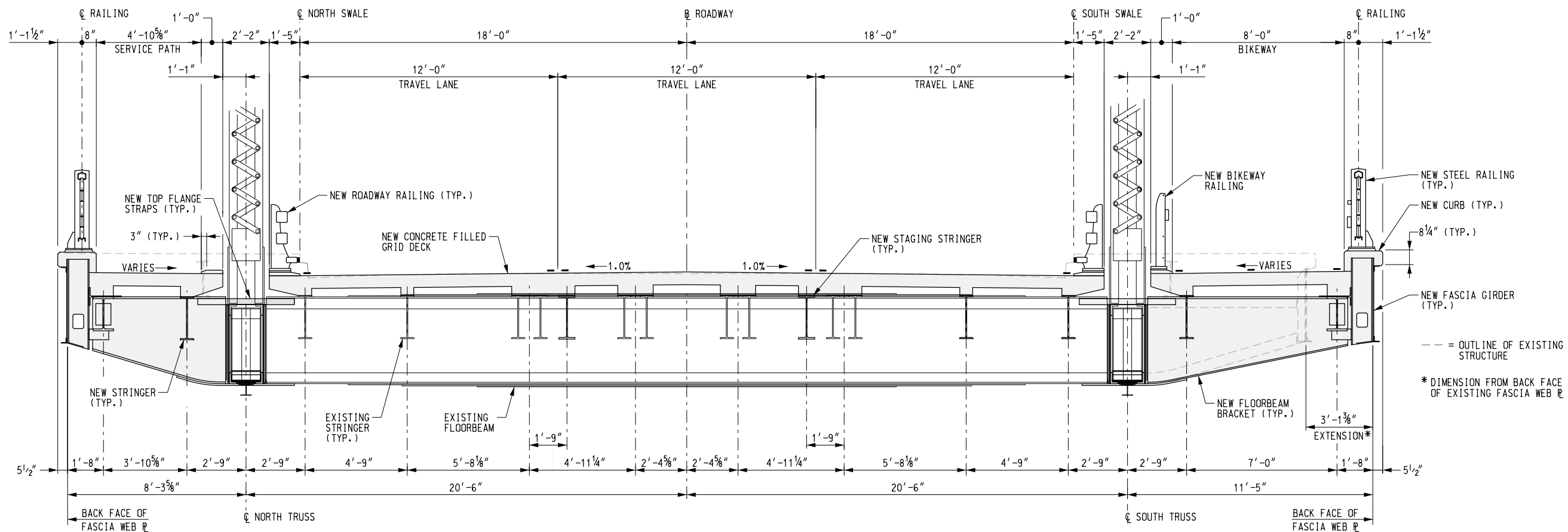

TYPICAL CROSS SECTION
SCALE: 3/16"=1'-0"

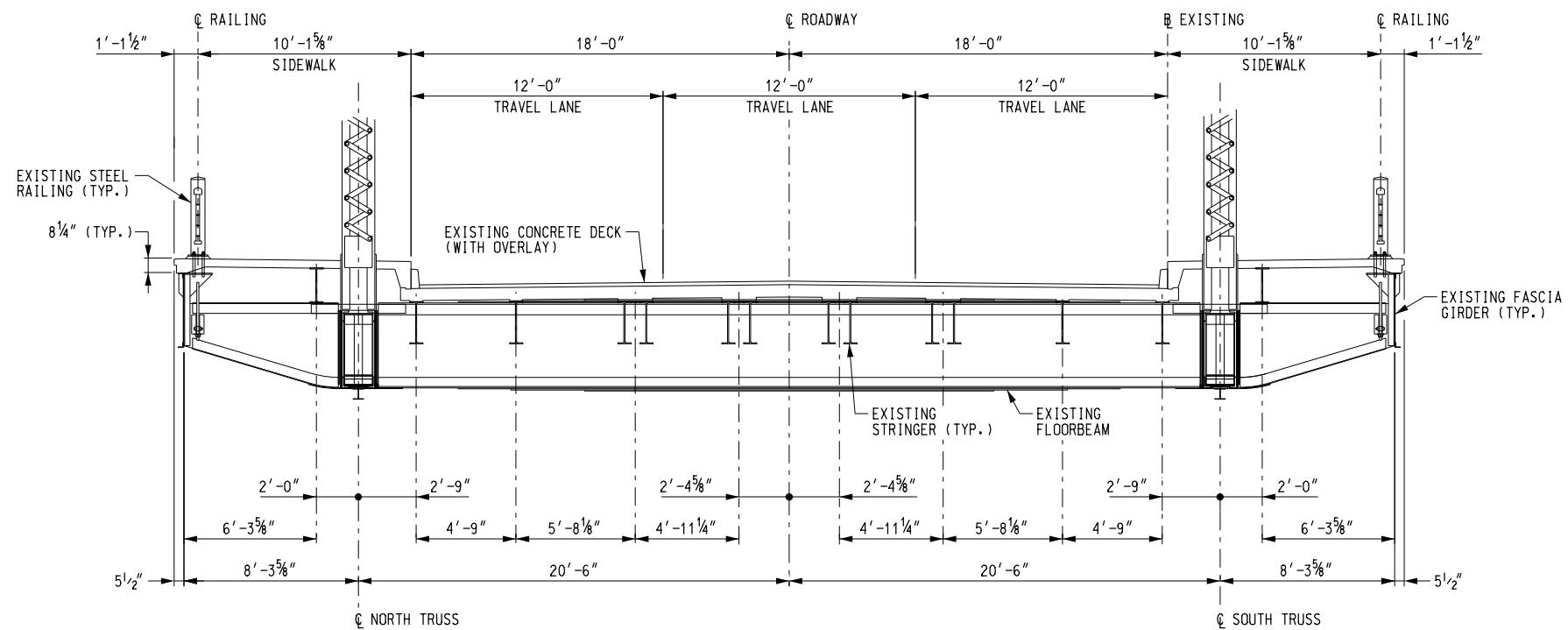

TYPICAL CROSS SECTION
SCALE: 1/8"=1'-0"

NOT FOR CONSTRUCTION



BUFFALO AND FORT ERIE
PUBLIC BRIDGE AUTHORITY

TRUSS SPAN
TYPICAL CROSS SECTION

SCALE: N.T.S.
DATE: OCT 2015

SHEET NO.
11 OF 14

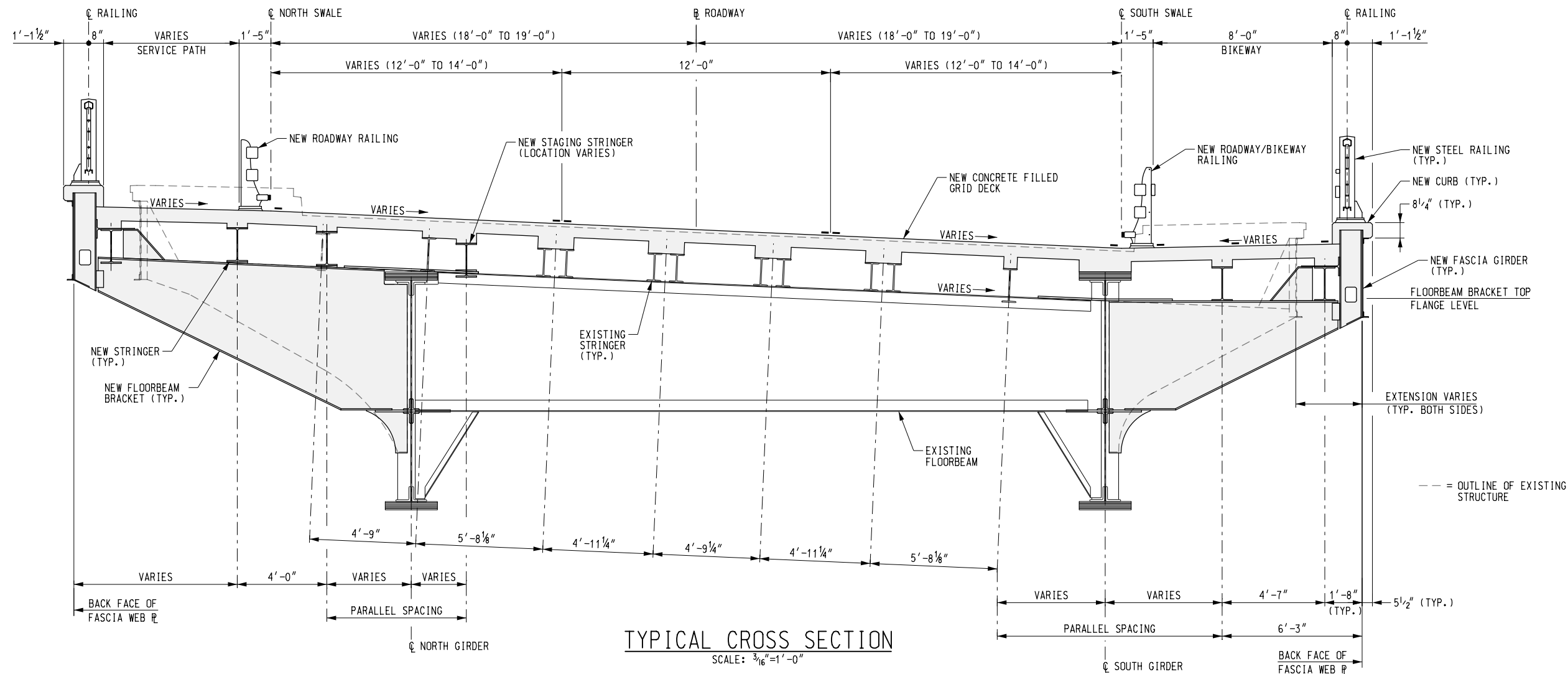

TYPICAL CROSS SECTION
SCALE: 3/16"=1'-0"

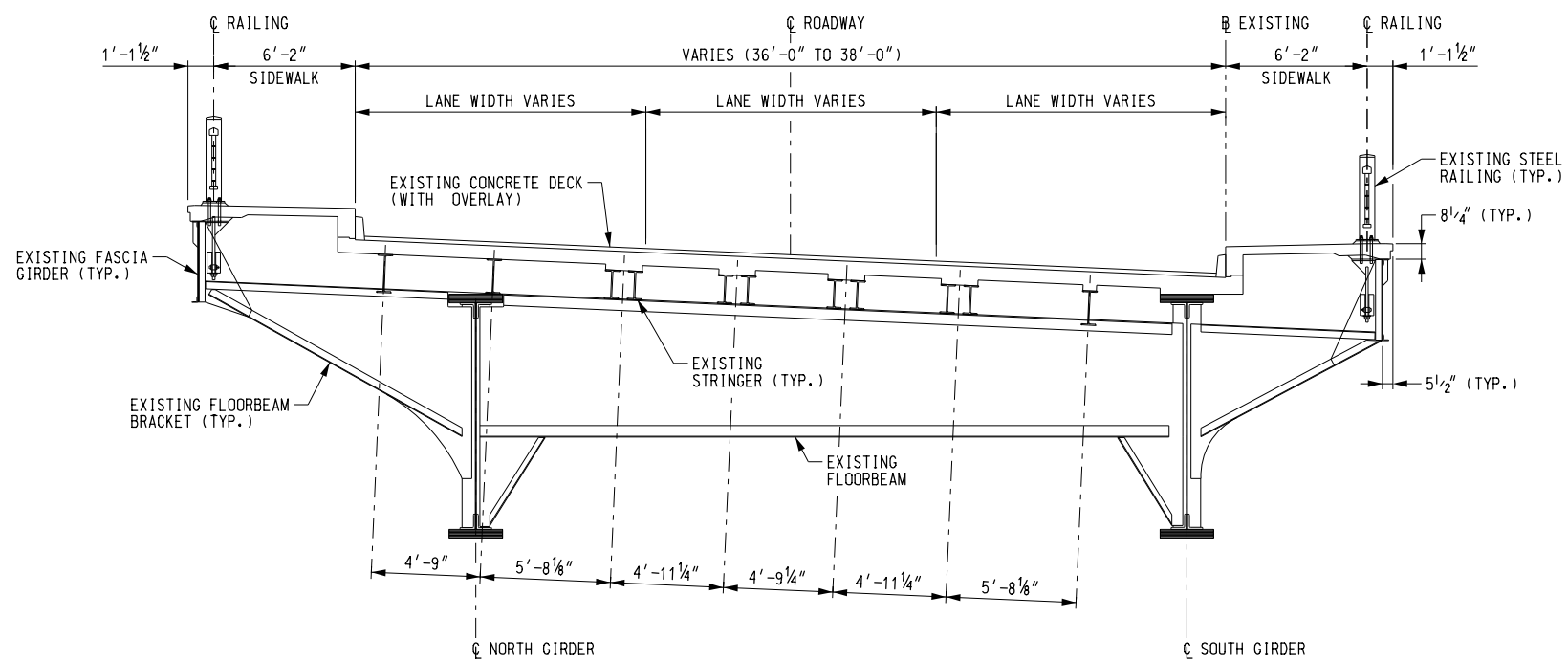

TYPICAL EXISTING CROSS SECTION
SCALE: 1/8"=1'-0"

NOT FOR CONSTRUCTION

 BUFFALO AND FORT ERIE PUBLIC BRIDGE AUTHORITY	SCALE: N.T.S.	SHEET NO.
	DATE: OCT 2015	12 OF 14

UNITED STATES APPROACH
CROSS SECTION (1 OF 3)

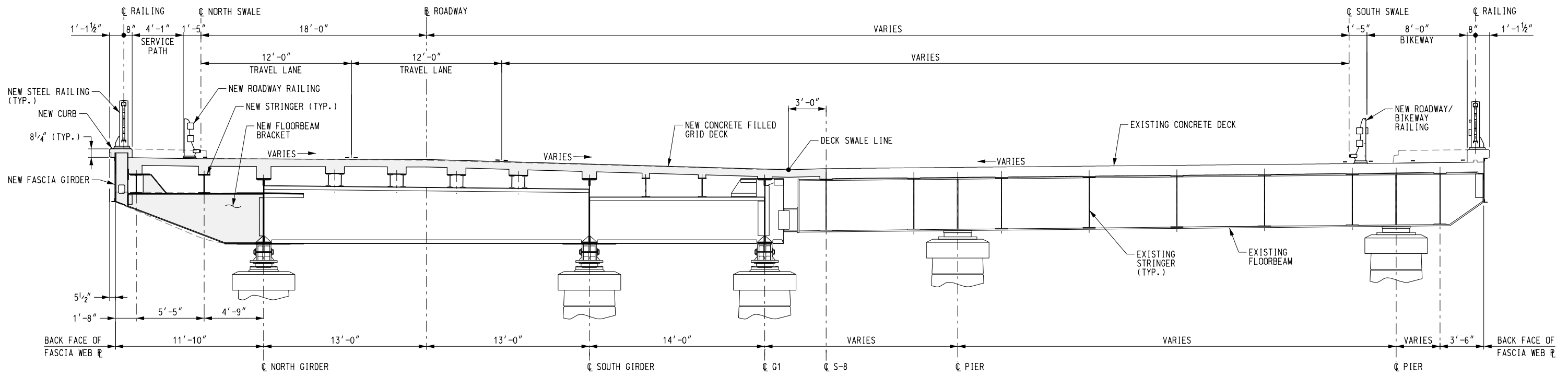

--- = OUTLINE OF EXISTING STRUCTURE

TYPICAL CROSS SECTION SPANS 35-37

SCALE: 1/8"=1'-0"

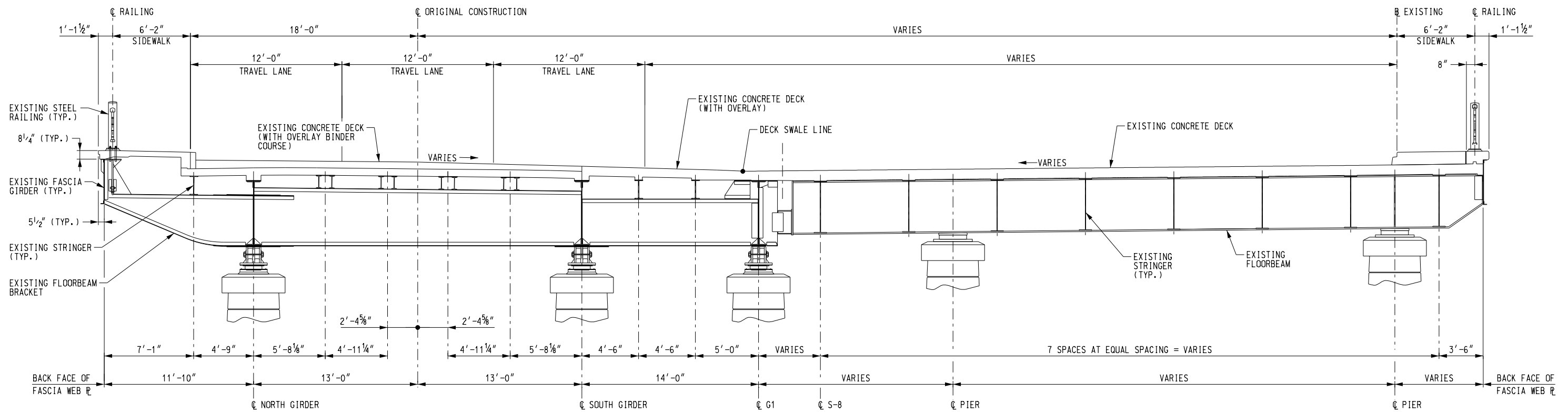

TYPICAL EXISTING CROSS SECTION SPANS 35-37

SCALE: 1/8"=1'-0"

NOT FOR CONSTRUCTION

 BUFFALO AND FORT ERIE PUBLIC BRIDGE AUTHORITY		
UNITED STATES APPROACH CROSS SECTION (3 OF 3)	SCALE: N.T.S. DATE: OCT 2015	SHEET NO. 14 OF 14